

Description of odometer GEL 2510

Construction and design

The GEL 2510 was specially developed for the reliable and exact acquisition of the mileage of axles on rail vehicles.

The maintenance-free and energy self-sufficient sensor obtains the necessary energy from the rotary movement of the axle and transmits the mileage and wagon data acquired to a mobile terminal using RFID.

The measuring system consists of a magnet assembly that, e.g., is fastened to the pressure plate for the wheel bearing and the GEL 2510. The latter is mounted on the exterior on the wheel bearing cover and features a low overall height of 25 mm. Due to the contactless magnetic scanning, the measuring system is mechanically de-coupled from the axle.

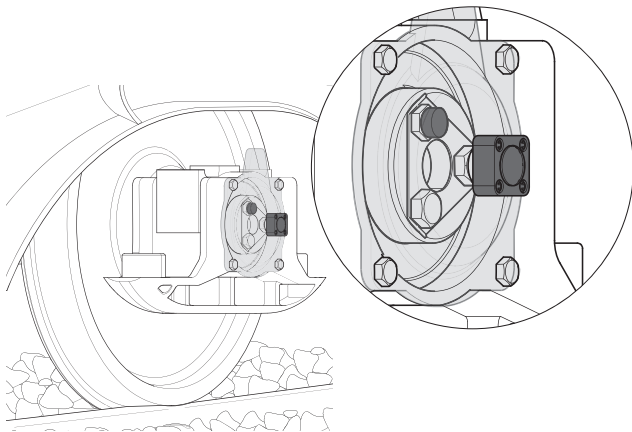

GEL 2510 mounted on wheel set bearing cover with magnet assembly mounted underneath

To be able to equip the most common wheel bearing types, 2 housing shapes are available. As a result the GEL 2510 can be integrated into existing wheel sets with little effort.

The fastening screws are protected by the protective caps, these caps are firmly pressed on after assembly. The protective caps cannot be removed without damaging them, as a result tampering can be detected at any time.

The odometer does not contain any wear parts and does not require a battery, as a consequence it is completely maintenance-free and extremely durable.

Function

The odometer is mounted on the existing wheel set bearing cover such that the active surface on the sensor can reliably detect the magnetic field from the magnet assembly.

If the wagon is in motion, the magnet rotates with the axle and therefore moves past the odometer's sensor surface. During this process it induces in the odometer pulses that are counted to acquire the mileage. Along with the mileage, the odometer registers any temperatures that exceed the stipulated temperature thresholds. In addition, the AC voltage provides the necessary energy to operate the odometer. The data acquired is saved in an internal non-volatile memory. While the wagon is stationary, the internal memory can be read using the reader GEL 2520 or can be written with data for sensor identification.

Technical data GEL 2510

Technical data - odometer GEL 2510

Odometer GEL 2510	
Supply voltage	No external (energy is generated by the rotation of the axle using a magnet/coil system; energy is supplied wirelessly via a reader to read the counter data)
Nominal voltage (internal)	6 V DC during reading; 4...19 V DC during operation
Operating and storage temperature range	-40 °C to +85 °C
Atmospheric humidity	0...98 %, condensing
Degree of protection	IP 68
Electromagnetic compatibility	As per EN 50121-3-2, CE mark
Shock resistance / vibration resistance	IEC 61373, cat. 3
Type test	EN 50155
Distance magnet/odometer	3.5 mm ± 3 mm
Housing material	Aluminium AlSi12, anodised
Weight	Approx. 250 g
Acquisition speed	From 30 rpm ⁽¹⁾
Max. speed	> 1200 rpm
Accuracy ⁽²⁾ <ul style="list-style-type: none"> • Typical tram application • Typical goods wagon application 	Maximum distance error: 3.0 % Typical distance error: 1.8 % Maximum distance error: 1.0 % Typical distance error: 0.4 %
Temperature monitoring	Threshold 70 °C and 85 °C
Conforms to	Radio Equipment Directive 2014/53/EU

Technical data - magnet assembly MG25104 / MG25105

Magnet assembly MG25104 / MG25105	
Version <ul style="list-style-type: none"> • MG25104 • MG25105 	Magnet on screw M20 × 60 M20 × 65
Property class DIN ISO 4017	10.9

⁽¹⁾ For average magnet/odometer distance of 3.5 mm

⁽²⁾ Dependent on the application

Dimensional drawings GEL 2510

Odometer GEL 2510 with design A / C

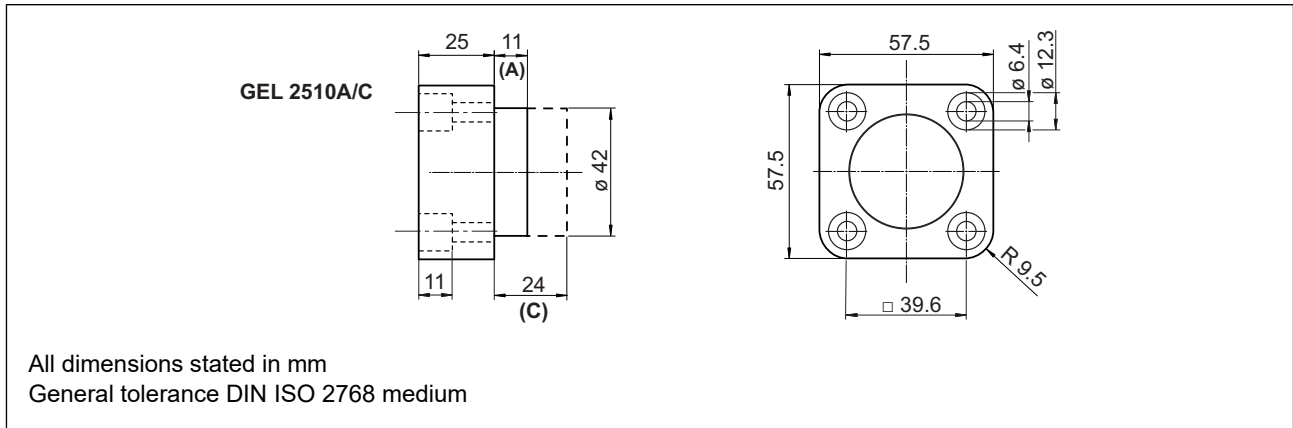

Magnet assemblies

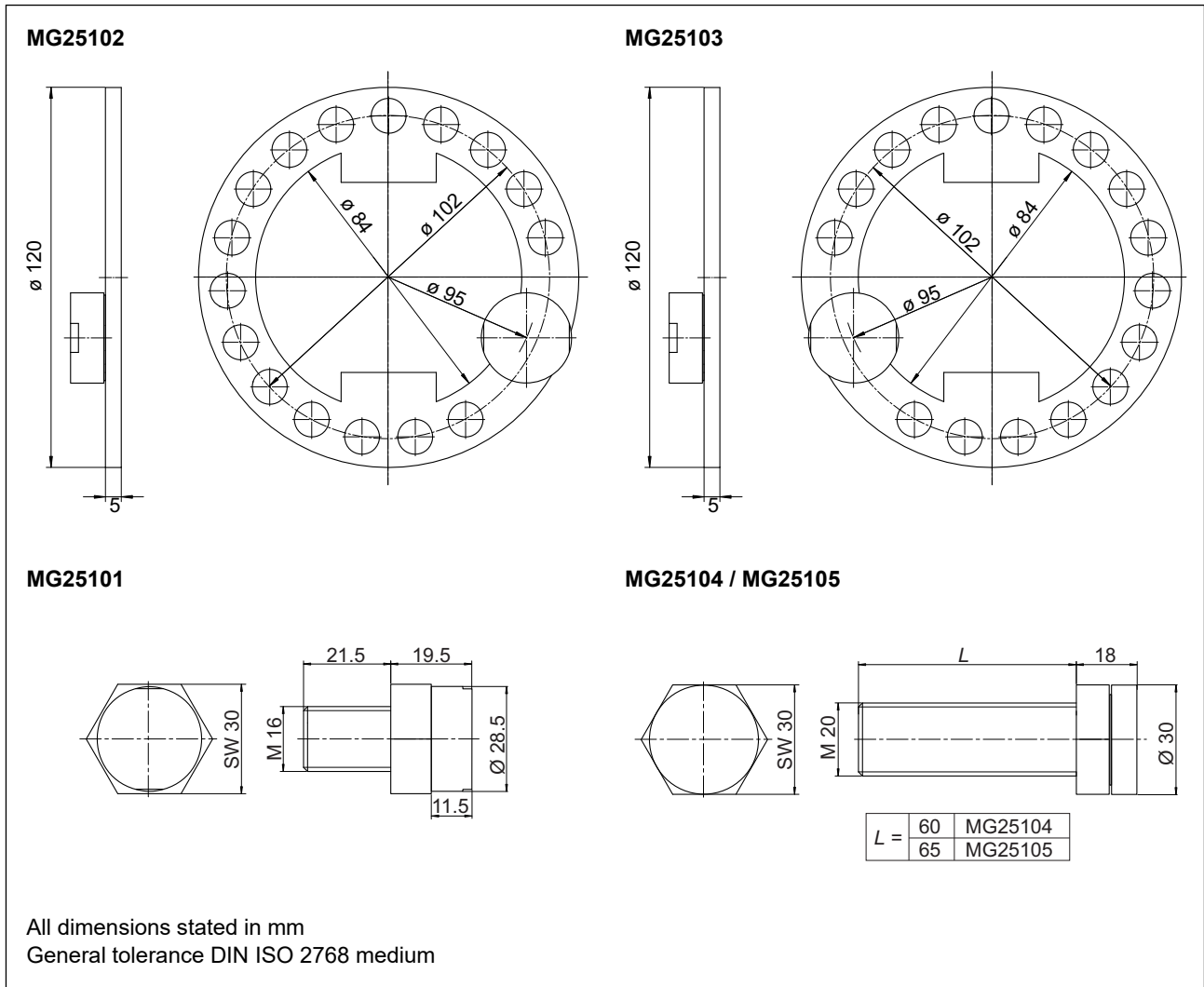

Type code and accessories GEL 2510

Type code

	Design
	A Short, straight
	C Long, straight
2510	—

Note: In general, customer-specific modifications to mechanical and electrical features are possible. Such special designs have the identifier GEL 2510Y..., are manufactured to drawing or application description, and can vary from the standard technical specification.

Mounting kit

The mounting kits are included in the scope of supply of the GEL 2510.

Design	Mounting kit	Scope of supply
A	MB25101	1 mounting kit: <ul style="list-style-type: none">1 flat gasket set4 fastening screws4 pairs of Nordlock locking washers4 protective caps for fastening screws
C	MB25101	1 mounting kit: <ul style="list-style-type: none">1 flat gasket set4 fastening screws4 pairs of Nordlock locking washers4 protective caps for fastening screws

Accessories

Description	Order no.
Magnet assembly, screw M16 x 21.5	MG25101
Magnet assembly, locking ring, magnet right	MG25102
Magnet assembly, locking ring, magnet left	MG25103
Magnet assembly, screw M20 x 60	MG25104
Magnet assembly, screw M20 x 65	MG25105
RFID reader, type Reader Odometer	GEL 2520

Description of GEL 2520 Reader Odometer

Configuration and data transmission

A mobile RFID reader is used to configure the odometer and to read the data acquired. The reader, a GEL 2520 Reader Odometer, is available as an accessory. To transmit data, the RFID area on the mobile reader is placed against the odometer with the vehicle/wagon stationary. To ensure correct data transmission, the reader confirms correctly completed data transmission with an acoustic signal.

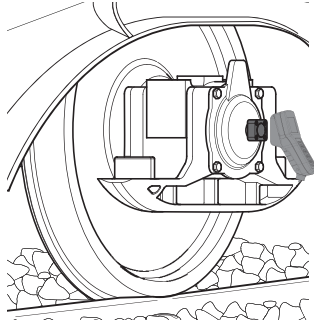

During each transmission all the data is read electronically, an error due to reading or allocating the data incorrectly is therefore not possible. The data in the odometer can only be read using the GEL 2520.

Further processing of the data

The reader can be connected to a PC using WLAN or using the USB port. The data collected can be further processed using common Office applications, ERP systems or maintenance programs.

USB port

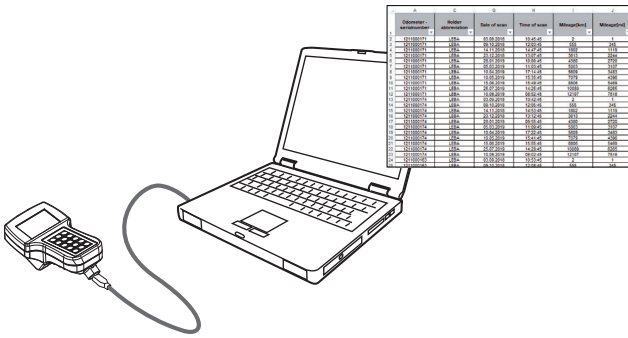

Via the USB port it is possible

- to charge the internal battery in the reader
- to access the records read from the odometers

WLAN connection



The reader communicates via WLAN with a client with web support (PC, tablet etc.) and is controlled via the web interface. For this purpose a current browser and a modern operating system for mobile terminals are required:

- Firefox 10+
- Safari 5.0+
- Chrome 16+
- Opera 10+
- Android 3.0+
- iOS 5.0+
- Internet Explorer 9+ (not recommended)

The web interface can be opened via the unit's IP address (can be configured; default: 192.168.141.1).

The web interface has been developed for mobile terminals such that it can be used even with small displays. For optimal operation, a display with a screen diagonal of 7 inches or greater is recommended.

Description of GEL 2520 Reader Odometer

GEL 2520 Reader Odometer

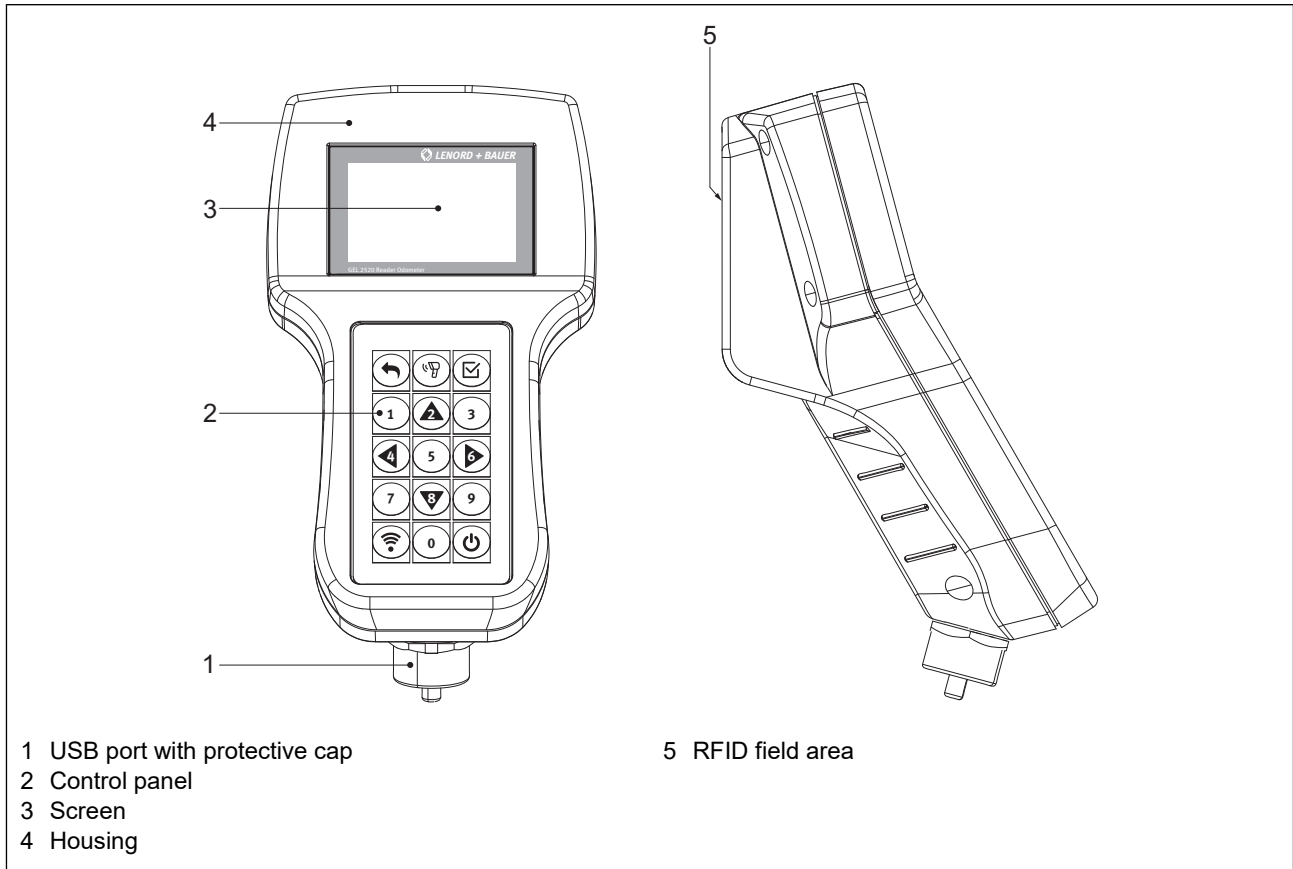

Measuring system – structure

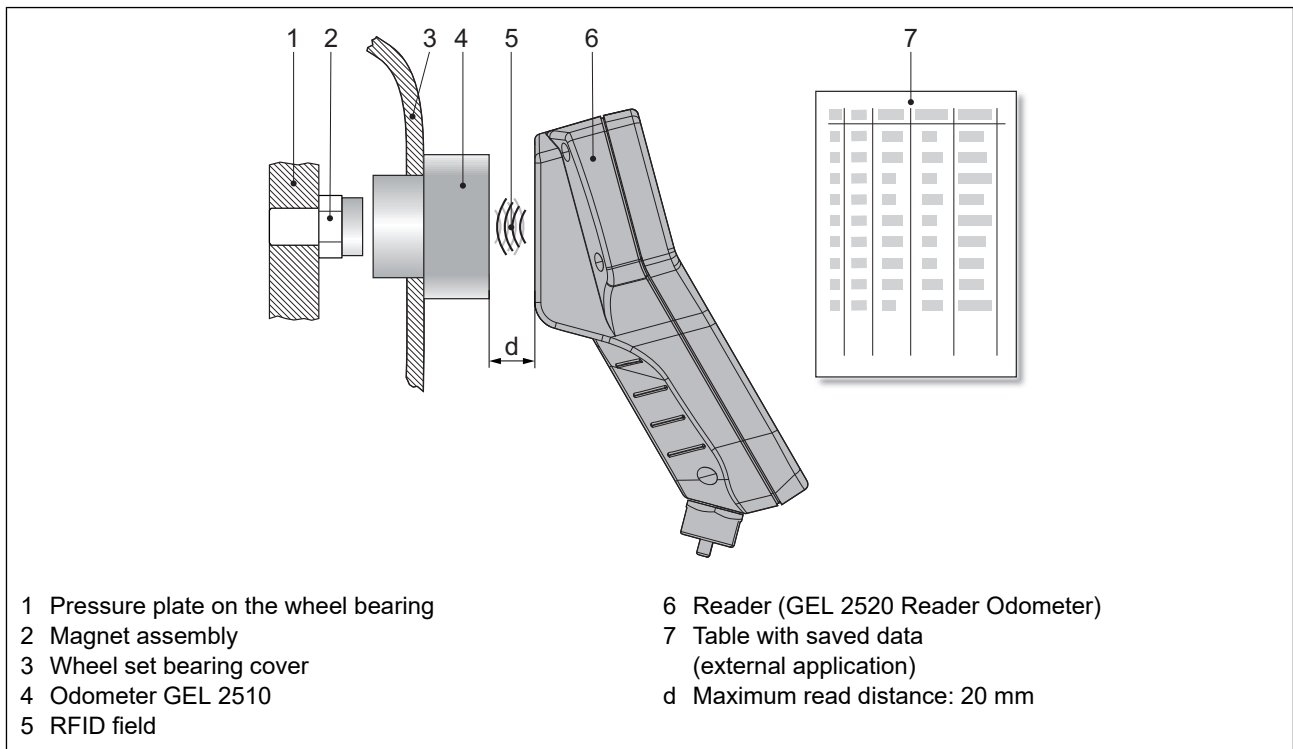

Technical data GEL 2520

Technical data reader

Electrical data	
Power supply (internal)	Lithium-ion battery (3.6 V, type 18650) External charging via the USB port (5 V / 500 mA; battery charging time < 5 hours)
Screen	128x64 LCD display with background lighting
Connection	USB (connector, type B) including screw cap
Mechanical data	
Housing material	Polyamide
Length of housing	186.6 mm
Width of housing	105.8 mm
Height of housing	70 mm
Weight	380 g incl. battery pack
Environmental data	
Operating temperature range	-10 °C to +50 °C
Storage temperature range	-20 °C to +60 °C
Dielectric strength	240 V AC / 330 V DC; compliant with DIN EN 62368-1:2016-05
ESD	DIN EN 61000-4-2: 2009-12
Shock resistance	DIN EN 60068-2-27:2010-02 DIN EN 60068-2-31: 2009-04
Vibration resistance	DIN EN 60068-2-6:2008-10
Max. relative humidity of air	DIN EN 60068-2-78:2014-02
Degree of protection	IP 65 according to EN 60529
RFID data	
Conforms to	Radio Equipment Directive 2014/53/EU
Transmission frequency	135 kHz
Maximum magnetic field strength at distance of 10 cm	0.58 A/m
WLAN data	
Conforms to	Radio Equipment Directive 2014/53/EU
FCC ID	2AC7Z-ESP32WROOM32U
IC ID	21098-ESPWROOM32
Frequency range	2400 ... 2483.5 MHz (IEEE 802.11 b/g/n)
Maximum transmission power	20 dBm

Dimensional drawing GEL 2520

Dimensional drawing reader

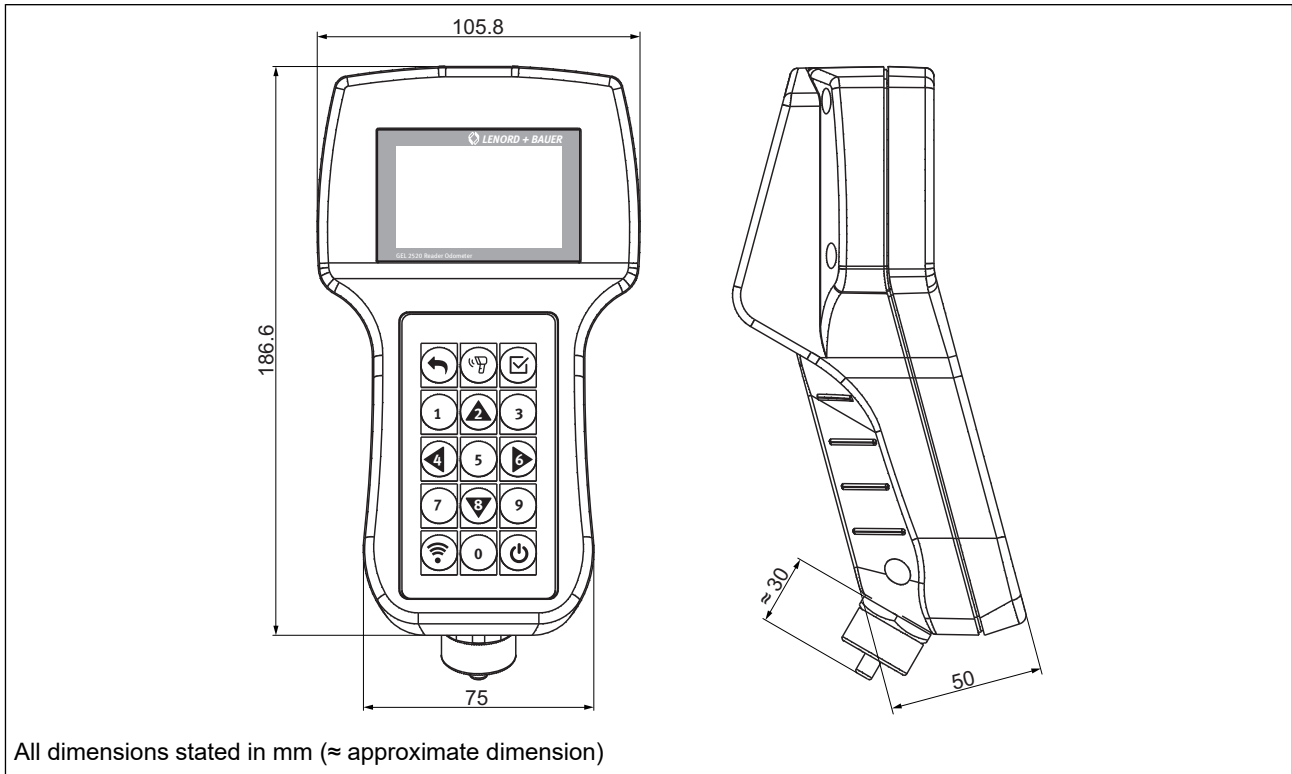

Notes:

Notes:



Lenord, Bauer & Co. GmbH
Dohlenstraße 32
46145 Oberhausen, Germany
Phone: +49 208 9963-0
Fax: +49 208 676292
Internet: www.lenord.com
E-Mail: info@lenord.de

Right to technical changes and errors reserved.