

MiniCODER

Configurable speed and position sensor with Mitsubishi interface

GEL 244xM

Technical information

Version 2023-09-26

General

- The measuring system comprises a MiniCODER and a target wheel for attachment to machine shafts.
- The MiniCODER scans the target wheel with magneto-resistive sensors without contact and detects the direction of rotation, speed and position.
- The MiniCODER can be adjusted and configured with the GEL 211CST4_2M testing and programming unit.

Properties

- MHSSI (Mitsubishi High Speed Serial Interface)
- Maximum permissible rotational speed:
Up to 100,000 min⁻¹ (1)
- Resolution: Up to 26 bits
- Operating temperature range: -30 °C to +105 °C
- Degree of protection: IP 68
- Position determination by reference mark detection

Advantages

- Maintenance-free electronics
- Wear-free mechanics
- Low temperature drift and high signal quality
- Highest interference immunity due to completely screened metal housing
- Fast commissioning of the configurable MiniCODER in the assembled state without opening the spindle with the testing and programming unit
- High design flexibility due to customized manufacture of target wheels

Field of application

- Position and rotational speed measurement in machine tool manufacturing

i All trademarks/brands quoted in this document are the property of their respective owner. Protected trademarks/brands are not marked as such in this document.

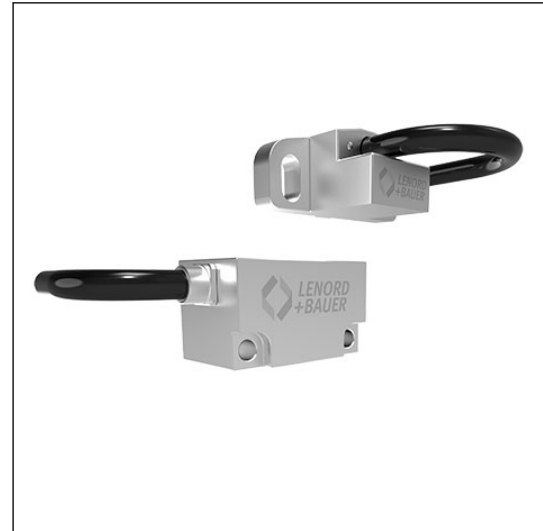

MiniCODER GEL 2449M/GEL 2444M

(1) Depending on the selected optional extras Mechanically permissible speed depending on the design of the target wheel (see Technical Information ZAx/ZFx (DS51–ZAx/ZFx)).

Right to technical changes and errors reserved.

General description

Product construction

MiniCODERs are intended for contactless measurement of rotational or linear movements mainly in machines, gear units, motors or high-speed spindles. They are manufactured using the latest micro system technology and are fully encapsulated, making them particularly insensitive to shocks and vibrations.

Measuring system

The measuring system comprises a MiniCODER and a target wheel. The system does not require dedicated bearings, as the target wheel is mounted directly on the machine shaft.

The measuring system works without contact and is wear-free with maintenance-free electrical parts. It detects the direction of rotation, rotational speed and position of a rotating machine shaft.

The target wheel is made of ferromagnetic material and must be ordered separately.

The MiniCODER has a magnetic field that is changed by the rotating target wheel. The sensor detects the magnetic field change and the integrated electronics convert this into corresponding output signals.

External electronics can read the output signals and determine the direction of rotation, rotational speed and position of the machine shaft.

A defined air gap between target wheel and MiniCODER is required for contactless measurement. To facilitate assembly, a corresponding distance gauge is included with the MiniCODER.

Reference mark

The MiniCODER can determine the machine shaft position by detecting a reference mark.

Module

The MiniCODER must be ordered to match the design of the reference mark and to match the module of the target wheel.

Explanations about the target wheel

Target wheels

For the detection of rotatory movements, MiniCODERs form a unit together with target wheels. The target wheel size and thus the diameter depend directly on the module and the number of teeth.

Standard target wheels

Standard target wheels are available at short notice ex factory. Specifications and designs see "Technical information ZA_x/ZF_x (DS51-ZA_x/ZF_x)".

Customized target wheels

Customized target wheels are manufactured individually according to customer requirements. Please send a design drawing of your target wheel to info@lenord.de.

Reference marks

The MiniCODER can detect reference marks of the lug or tooth form. The detected reference signal can be used to reference the position. This is required, for example, for automatic changing of a tool on a milling or grinding spindle.

Selection of the reference mark is determined by the size and rotational speed of the target wheel used, as both

affect the forces acting on the reference mark. For new designs, we recommend using a target wheel with reference mark variant "Z".

Reference mark N – lug

A metal lug integrated in the target wheel, whose position is exactly between two teeth, is detected. The lug must be made of ferromagnetic material and must not protrude beyond the tip circle of the target wheel. Due to the forces acting on the reference lug, the use of this variant is only permissible in a very limited rotational speed range.

Reference mark Z – tooth on tooth

These target wheels are made from a single piece.

Module

The module is a tothing dimension for target wheels and describes the relationship between the number of teeth and the pitch diameter of the target wheel. For the same number of teeth, the smaller the module, the smaller the outside diameter.

i The MiniCODER must be ordered to match the design of the reference mark and to match the module of the target wheel.

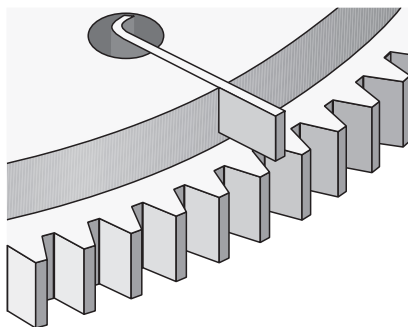

N = reference mark – lug

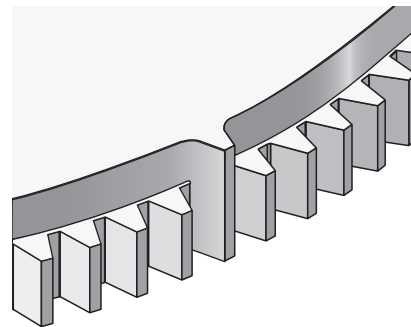

Z = reference mark – lug
Standard target wheel

General description

Connection types

L = Cable length



The connection cable screen is electroconductively connected to the MiniCODER housing.

Connection example with GEL 2449M

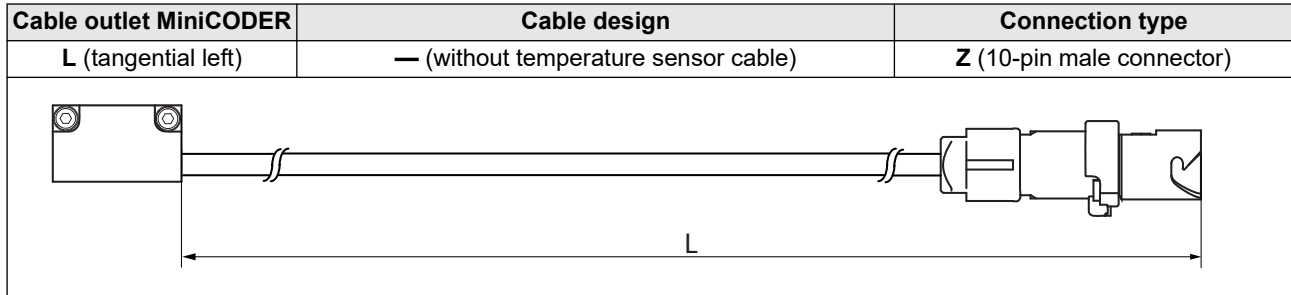

Assignments

Connection type K

Flying lead (10-pin female connector ¹⁾) (plug-in view)	Pin	Core color	Signal/Function	
	1	red	U_B	+5 V supply voltage
	2	white	RQ+	Positive request signal
	3	brown	RQ-	Inverse request signal
	4	pink	Data+	Positive data
	5	black	Data-	Inverse data
	6	green	n.c.	unallocated
	7	gray	n.c.	unallocated
	8	yellow	n.c.	unallocated
	9	blue	0 V	GND
	10	unallocated		

¹⁾ The delivery takes place with connected test connector from Lenord+Bauer.



If a testing and programming unit is to be used for the function test, the test plug must not be removed!

General description

Connection type Z

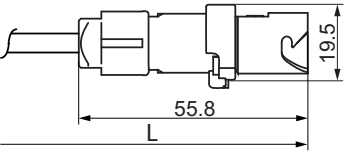
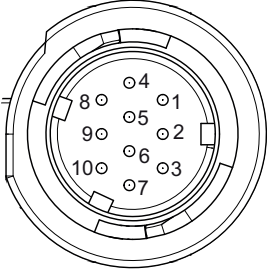
10-pin male connector (plug-in view)	Pin	Signal/Function	
	1	n.c.	unallocated
	2	n.c.	unallocated
	3	RQ+	Positive request signal
	4	RQ-	Inverse request signal
	5	Data+	Positive data
	6	Data-	Inverse data
	7	U _B	+ 5 V power supply
	8	0 V	GND
	9	Screen	Screen
	10	n.c.	unallocated

General description of the MHSSI interface

Signal pattern M

The MiniCODER GEL 244xM is an incremental rotary encoder with reference signal. It transmits data via a digital serial interface (Mitsubishi High Speed Serial Interface).

Data transmission only takes place upon request. The MiniCODER decodes incoming requests (RQ+/RQ-) from a higher level control system and then sends the requested data (Data+/Data-) to the higher level control system.

The MiniCODER can be connected directly to the following Mitsubishi higher level control systems:

Possible applications

Mitsubishi CNC series M800/M80/E80/C80	
Spindle drive	Servo drive
Model <ul style="list-style-type: none"> ▪ MDS-E-SP series ▪ MDS-EH-SP series ▪ MDS-EJ-SP series ▪ MDS-EM-SP series ▪ MDS-EMH-SP series 	Model <ul style="list-style-type: none"> ▪ MDS-E-Vx series ▪ MDS-EH-Vx series ▪ MDS-EJ-Vx series ▪ MDS-EJH-Vx series ▪ MDS-EM-Vx series ▪ MDS-EMH-Vx series
Firmware number: BND-1501W202	Firmware number: BND-1501W201
Firmware version: B2 or higher	Firmware version: B2 or higher



Plug and Play

Any target wheel diameters are possible for freely selectable teeth numbers. The application can be connected directly to Mitsubishi higher level control systems by configuring the measuring system with the testing and programming unit.

Alarm and warning table

Alarm number (MiniCODER connected with CN2)	2B	2C	2D	2E	48	49	4A	4B
Alarm number (MiniCODER connected with CN3)	1B	1C	1D	1E	27	28	29	2A
GEL 244xM... (ID: 9F)	Signal error	Amplitude warning	EEPROM error	Under voltage	Hardware error	Warning overspeed	Counter error	Temperature warning

Optional extras H, P (configurable)

The MiniCODER can be tested and configured with the GEL 211CST4_2M testing and programming unit.

The following functions are available:

- MiniCODER functional test
- Target wheel functional test
- Changing the resolution and the number of target wheel teeth
- Determining the parameters to be set on the higher level control system



If the number of teeth set in the MiniCODER in the factory does not match the number of teeth of the target wheel, the number of teeth in the MiniCODER must be adjusted to the number of teeth of the target wheel using the testing and programming unit.

Testing and programming unit GEL 211CST4_2M



- Analysis, optimization and parameterization of the MiniCODERs with digital RS422/RS485 interface, for example, GEL 244xM
- Compact and mobile
- Plug and play: Connection to the MiniCODER via the external connector; no disassembly required
- Menu-driven adjustment to optimize the signal quality in the installed state
- Checking the quality and installation situation of the target wheel
- Easy operation via web browser on any end device such as smartphone, tablet or PC, no software installation necessary
- Communication via LAN or WLAN

Accessories GEL 244_M

Item no.:	Designation:
ZB2449M1	Adapter cable 3.0 m for GEL 244_M_...Z_... (connection to Mitsubishi higher level control systems)
ZB2449M3	Adapter cable 2.0 m for GEL 244_M_...Z_... (connection to Mitsubishi higher level control systems)
PK211C-244XM-E	PK211C-244XM-E (Ethernet), comprising: <ul style="list-style-type: none"> ▪ Testing and programming unit GEL 211CST4E2M ▪ Universal adapter box, ZB2449M4 ▪ Power supply unit 5 V, ZB211CB ▪ Operating instructions, D-71B-211C ▪ Case, XW1303
PK211C-244XM-W	PK211C-244XM-W (WLAN), comprising: <ul style="list-style-type: none"> ▪ Testing and programming unit GEL 211CST4W2M ▪ Universal adapter box, ZB2449M4 ▪ Power supply unit 5 V, ZB211CB ▪ Operating instructions, D-71B-211C ▪ Case, XW1303

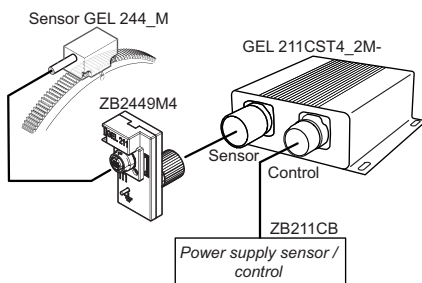

GEL 211CST4_2M: Connectivity

GEL 2444M

Technical data measuring system

	GEL 2444M_...3	GEL 2444M_...4	GEL 2444M_...5
Target wheel			
Material	Ferromagnetic steel		
Target wheel width	10.0 mm		
Reference mark	Lug (N), tooth (Z)		
Module m ⁽¹⁾	0.3	0.4	0.5
Geometric data			
Nominal air gap	0.15 mm ± 0.02 mm	0.20 mm ± 0.02 mm	0.20 mm ± 0.03 mm

(1) Other modules upon request

Technical data GEL 2444M

Electrical data	
Supply voltage U_B (polarity reversal protected, overvoltage protected)	5 V DC \pm 5 %
Current consumption (without load)	\leq 80 mA
Digital interface	RS485 with Mitsubishi protocol: MHSSI (Mitsubishi High Speed Serial Interface) 2.5 Mbit (RS422/RS485 compliant)
Signal identifiers of the interface	Request (RQ): Data request signal from the higher level control system Data (data): Data output from the MiniCODER as a response to the data request signal
Data transmission rate	2.5 Mbit/s
Power consumption without load	\leq 0.5 W
Power-on time	< 0.5 s
Mechanical data	
Housing material	Zinc die casting
Weight	30 g
Maximum permissible rotational speed	\leq 100,000 min ⁻¹ (1)
Cable data	
Cable structure (number of cores x core cross-section)	9 x 0.15 mm ² (25 AWG)
Cable diameter	5 mm
Minimum bending radius	25 mm
Maximum permissible cable length	\leq 30 m (2)
Ambient data	
Working temperature range	0 °C to +70 °C
Operating and storage temperature range	-30 °C to +105 °C
Degree of protection	IP 68
Dielectric strength	500 V AC; as per DIN EN 61439-1
Electromagnetic compatibility	Electromagnetic emission DIN EN 61000-6-4; DIN EN 61000-6-3 Electromagnetic immunity DIN EN 61000-6-2; DIN EN 61000-6-1
Vibration resistance	200 m/s ² (EN 60068-2-6)
Shock resistance	2000 m/s ² (EN 60068-2-27)
MTTF FIT	4,325,201 h at 55 °C 231.203 10 ⁻⁹ h ⁻¹ at 55 °C
Approvals	
European Economic Area	Conformity in accordance with EMC Directive 2014/30/EU CE

(1) Depending on the selected optional extras Mechanically permissible speed depending on the design of the target wheel (see Technical Information ZAx/ZFx (DS51-ZAx/ZFx)).

(2) Consider voltage drop on the power supply cable; recommended cable length: maximum 2.5 m (no twisted pair)

GEL 2444M

Optional extras H

Resolution

For MiniCODERs with optional extras H, the resolution is independent of the number of teeth of the target wheel and the maximum speed. The resolution can be adapted to the respective application if required. The maximum configurable resolution is 26 bits/0.0000054° (67,108,864 positions per revolution).

Factory settings⁽¹⁾

Designation	Module 3 (m= 0.3)	Module 4 (m= 0.4)	Module 5 (m= 0.5)
Positions per revolution	16777216	16777216	16777216
Resolution	24 bit/0.0000215°	24 bit/0.0000215°	24 bit/0.0000215°
Target wheel tooth number	256	192	150

Optional extras P

Resolution for various applications⁽²⁾

Application	Standard		Rotational speed					Positioning
Interpolation per tooth cycle	512		256					1024
Target wheel tooth number	128	192	160	204	256	384	512	512
Maximum rotational speed (min ⁻¹) ⁽³⁾	41,199	27,466	65,918	51,700	41,199	27,466	20,599	5150
Positions per revolution	65,536	65,536	32,768	32,768	65,536	65,536	131,072	524,288
Resolution	16 bit/0.00549°	16 bit/0.00549°	15 bit/0.0110°	15 bit/0.0110°	16 bit/0.00549°	16 bit/0.00549°	17 bit/0.00274°	19 bit/0.00068°

Calculation of the maximum rotational speed

$$\text{Maximale Drehzahl} = \frac{2,7 \cdot 10^9}{\text{Zähnezahl} \cdot \text{Interpolation}} \text{ min}^{-1}$$

Factory settings⁽¹⁾

Designation	Module 3 (m= 0.3)	Module 4 (m= 0.4)	Module 5 (m= 0.5)
Interpolation per tooth cycle	512	512	512
Target wheel tooth number	256	192	150

Assignment direction of rotation

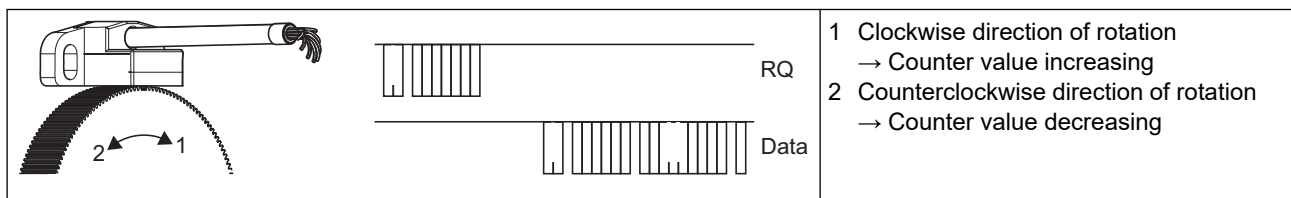

If you have any questions, please contact our Customer Support team (e-mail: support@lenord.de) or one of our company locations (→ [page 24](#)).

⁽¹⁾ Other factory settings are available upon request.

⁽²⁾ Others upon request

⁽³⁾ The maximum speed is limited by the internal electronics. The maximum mechanical speed depends on the selection of the target wheel.

Dimensional drawings

All dimensions in millimeters; general tolerance DIN ISO 2768 – mK

Dimensional drawing cable outlet MiniCODER: Radial (R)

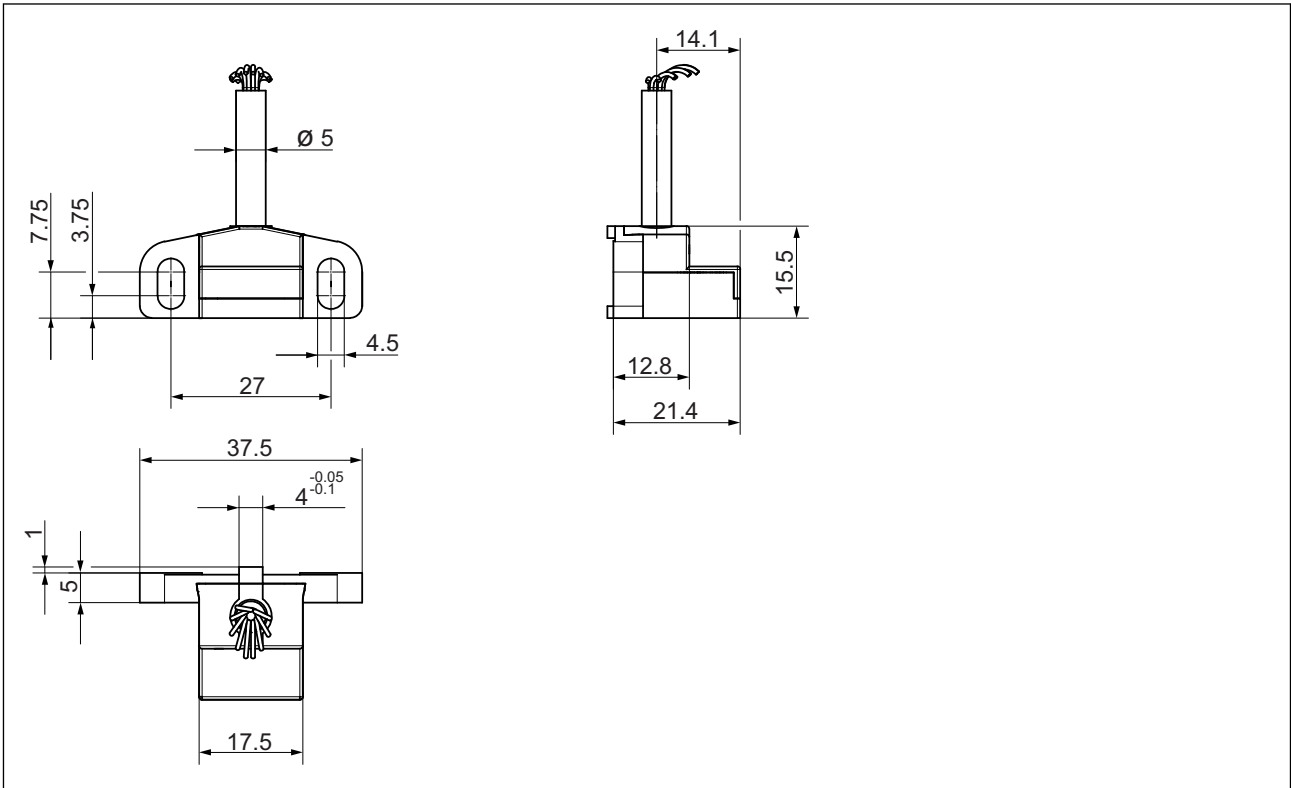

Dimensional drawing cable outlet MiniCODER: Axial (G)

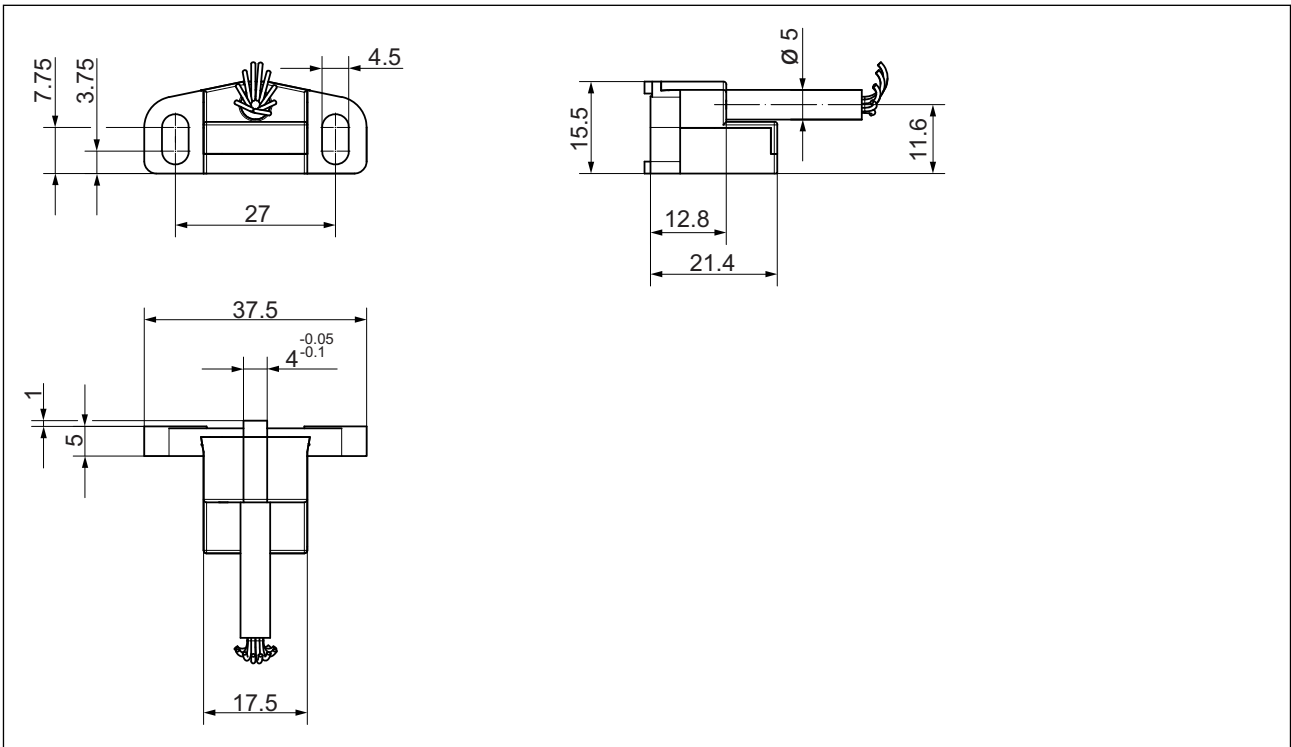

GEL 2444M

Dimensional drawing cable outlet MiniCODER: Tangential right (T)

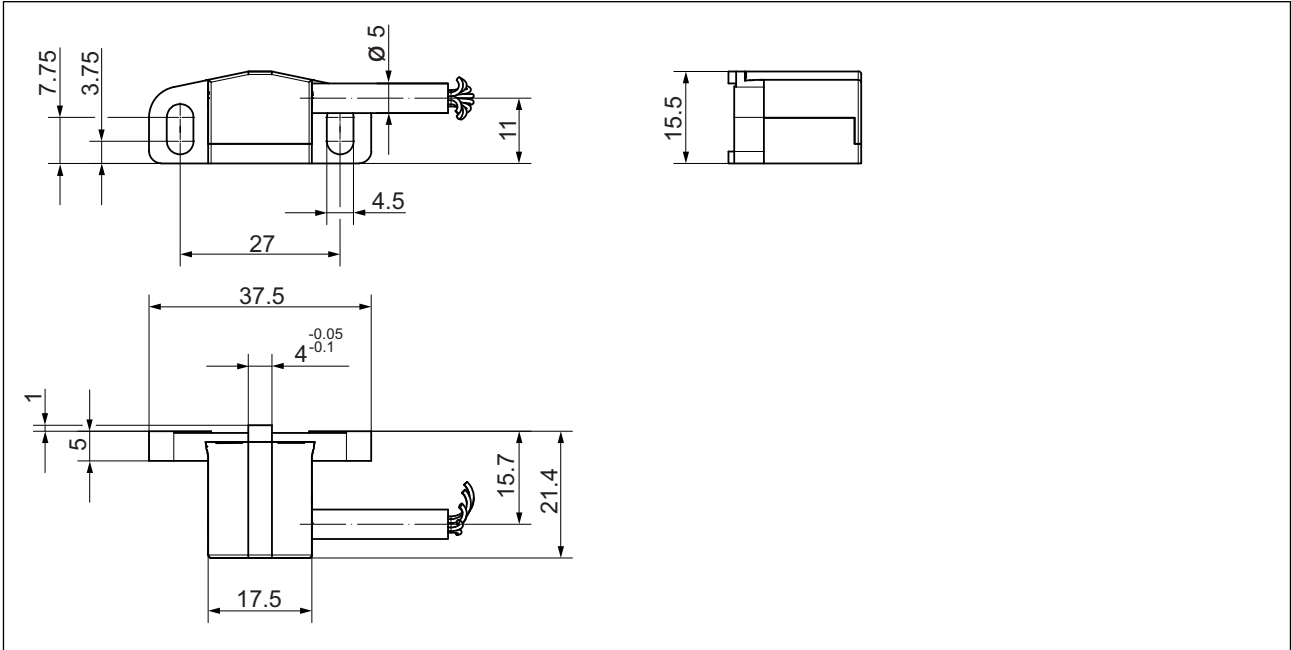

Dimensional drawing cable outlet MiniCODER: Tangential left (L)

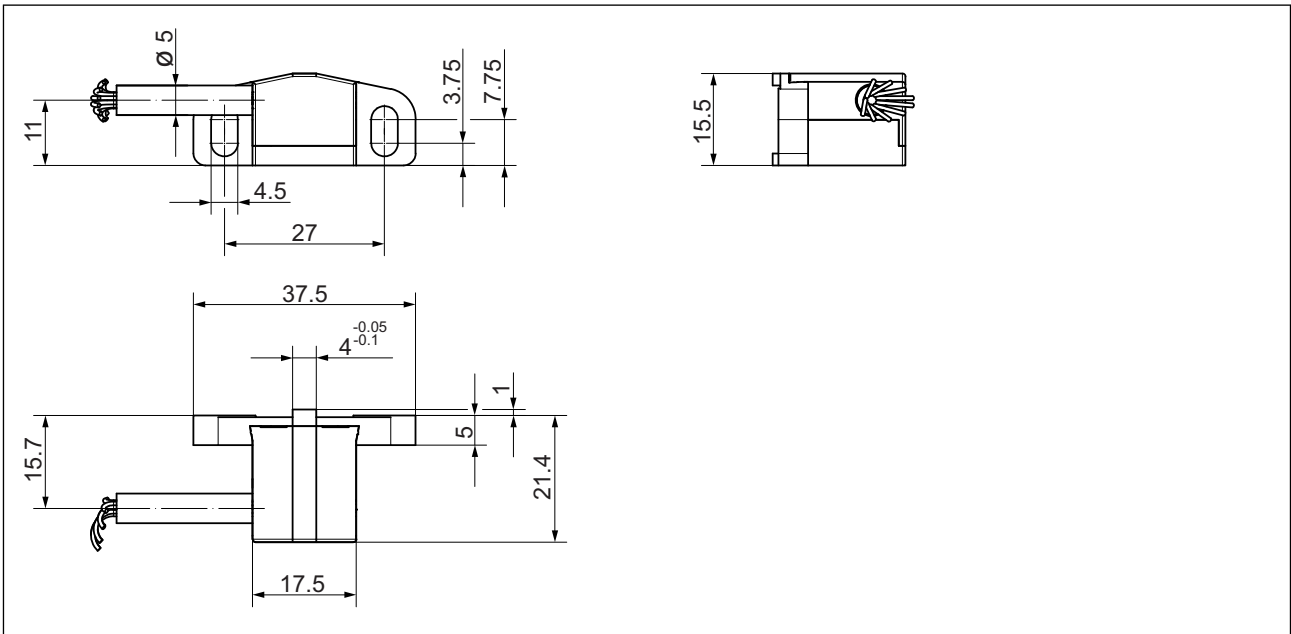

Hole pattern and installation dimensions

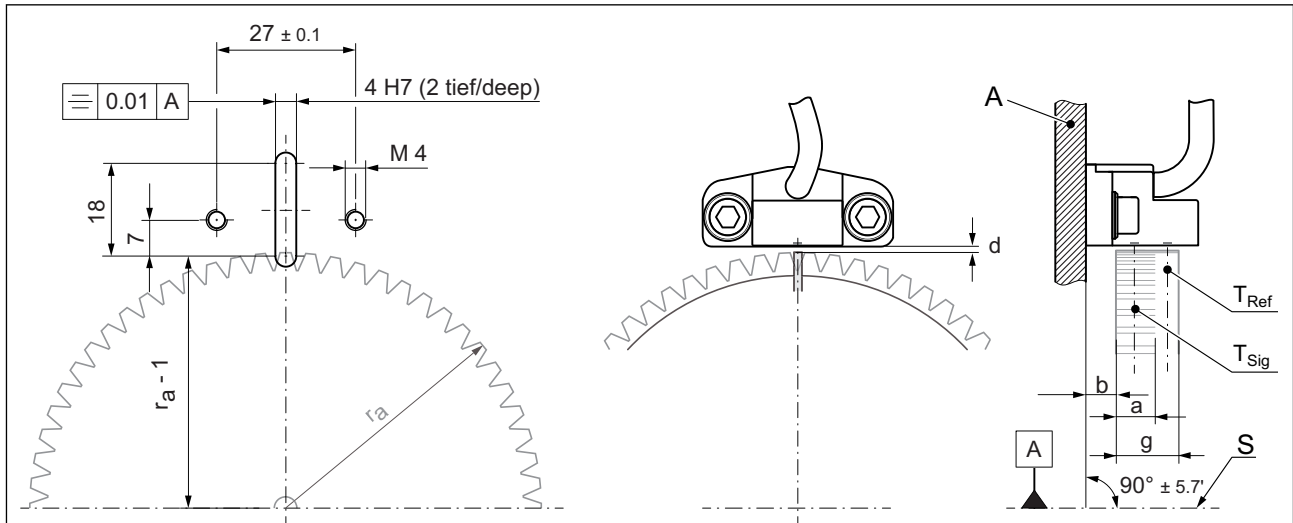

All dimensions in mm

- a Width of the signal track (depending on the target wheel)
- b Distance from mounting surface to target wheel: depending on the target wheel geometry (for example, width of signal track)
- d Air gap: depending on the module (→ page 8)
- g Target wheel width
- $r_a = d_a/2$ (with d_a = target wheel tip circle diameter)
- A Mounting device
- S Center line machine shaft/target wheel
- T_{Ref} Reference track (target wheel)
- T_{Sig} Signal track (target wheel)

Installation dimensions for standard target wheels

Dimension	ZAN	ZAZ
g	10	10
$a_{1/2}$	4	6
a_N	4	4
b	7.5 ± 0.5	7.5 ± 0.5

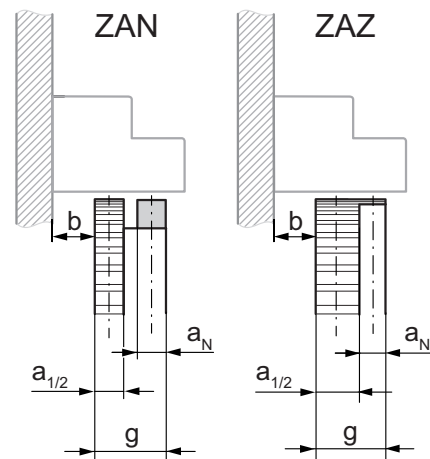

GEL 2444M

Type code

2444	Signal pattern	
	M	MHSSI (Mitsubishi High Speed Serial Interface) 2.5 Mbit
	Reference mark	
	N	Lug ⁽¹⁾
	Z	Tooth on tooth
	Optional extras	
	H	Configurable (resolution is independent of speed)
	P	Configurable (resolution is dependent on speed)
	Cable outlet MiniCODER	
	R	Radial
G	Axial	
T	Tangential, cable outlet right	
L	Tangential, cable outlet left	
Module ⁽²⁾		
3	m= 0.3	
4	m= 0.4	
5	m= 0.5	
Connection type		
K	Flying lead	
Z	10-pin male connector (only available as cable length 100/120/200/250)	
Cable length L		
030	0.3 m	
050	0.5 m	
100	1.0 m	
120	1.2 m	
150	1.5 m	
200	2.0 m	
250	2.5 m	
Cable design for temperature sensor (2 m)		
-	Without temperature sensor cable	



For MiniCODERs with optional extras **H** or **P** the resolution and the number of teeth can be configured with the testing and programming unit. You can find the factory settings on → [page 10](#). Other factory settings are available upon request.



Technical information on MiniCODERs with other signal patterns is available online at www.lenord.com or can be requested from our support team (support@lenord.de).

⁽¹⁾ MiniCODERs that scan a reference mark "N" (lug) must be recalibrated with the test and programming unit during commissioning.

⁽²⁾ Other modules upon request

Technical data measuring system

	GEL 2449M _{...} 1	GEL 2449M _{...} 4
Target wheel		
Material	Ferromagnetic steel	
Target wheel width	10.0 mm	
Reference mark	Tooth (Z)	
Module m ⁽¹⁾	1.0	0.4
Geometric data		
Nominal air gap	0.50 mm ± 0.03 mm	0.20 mm ± 0.02 mm

⁽¹⁾ Other modules upon request

GEL 2449M

Technical data GEL 2449M

Electrical data	
Supply voltage U_B (polarity reversal protected, overvoltage protected)	5 V DC \pm 5 %
Current consumption (without load)	\leq 80 mA
Digital interface	RS485 with Mitsubishi protocol: MHSSI (Mitsubishi High Speed Serial Interface) 2.5 Mbit (RS422/RS485 compliant)
Signal identifiers of the interface	Request (RQ): Data request signal from the higher level control system Data (data): Data output from the MiniCODER as a response to the data request signal
Data transmission rate	2.5 Mbit/s
Power consumption without load	\leq 0.5 W
Power-on time	< 0.5 s
Mechanical data	
Housing material	Zinc die casting
Weight	100 g
Maximum permissible rotational speed	\leq 100,000 min ⁻¹ (1)
Cable data	
Cable structure (number of cores x core cross-section)	9 x 0.15 mm ² (25 AWG)
Cable diameter	5 mm
Minimum bending radius	25 mm
Maximum permissible cable length	\leq 30 m (2)
Ambient data	
Working temperature range	0 °C to +70 °C
Operating and storage temperature range	-30 °C to +105 °C
Degree of protection	IP 68
Dielectric strength	500 V AC; as per DIN EN 61439-1
Electromagnetic compatibility	Electromagnetic emission DIN EN 61000-6-4; DIN EN 61000-6-3 Electromagnetic immunity DIN EN 61000-6-2; DIN EN 61000-6-1
Vibration resistance	200 m/s ² (EN 60068-2-6)
Shock resistance	2000 m/s ² (EN 60068-2-27)
MTTF FIT	3,828,120 h at 55 °C 261 10 ⁻⁹ h ⁻¹ at 55 °C
Approvals	
European Economic Area	Conformity in accordance with EMC Directive 2014/30/EU CE

(1) Depending on the selected optional extras Mechanically permissible speed depending on the design of the target wheel (see Technical Information ZAx/ZFx (DS51-ZAx/ZFx).

(2) Consider voltage drop on the power supply cable; recommended cable length: maximum 2.5 m (no twisted pair)

Optional extras H

Resolution

For MiniCODERs with optional extras H, the resolution is independent of the number of teeth of the target wheel and the maximum speed. The resolution can be adapted to the respective application if required. The maximum configurable resolution is 26 bits/0.0000054° (67,108,864 positions per revolution).

Factory settings⁽¹⁾

Designation	Module 4 (m= 0.4)	Module 1 (m= 1.0)
Positions per revolution	16777216	16777216
Resolution	24 bit/0.0000215°	24 bit/0.0000215°
Target wheel tooth number	192	75

Optional extras P

Resolution for various applications⁽²⁾

Application	Standard		Rotational speed					Positioning
Interpolation per tooth cycle	512		256					1024
Target wheel tooth number	128	192	160	204	256	384	512	512
Maximum rotational speed (min ⁻¹) ⁽³⁾	41,199	27,466	65,918	51,700	41,199	27,466	20,599	5150
Positions per revolution	65,536	65,536	32,768	32,768	65,536	65,536	131,072	524,288
Resolution	16 bit/ 0.00549°	16 bit/ 0.00549°	15 bit/ 0.0110°	15 bit/ 0.0110°	16 bit/ 0.00549°	16 bit/ 0.00549°	17 bit/ 0.00274°	19 bit/ 0.00068°

Calculation of the maximum rotational speed

$$\text{Maximale Drehzahl} = \frac{2,7 \cdot 10^9}{\text{Zähnezahl} \cdot \text{Interpolation}} \text{ min}^{-1}$$

Factory settings⁽¹⁾

Designation	Module 4 (m= 0.4)	Module 1 (m= 1.0)
Interpolation per tooth cycle	512	512
Target wheel tooth number	192	75

Assignment direction of rotation



If you have any questions, please contact our Customer Support team (e-mail: support@lenord.de) or one of our company locations (→ [page 24](#)).

⁽¹⁾ Other factory settings are available upon request.

⁽²⁾ Others upon request

⁽³⁾ The maximum speed is limited by the internal electronics. The maximum mechanical speed depends on the selection of the target wheel.

GEL 2449M

Dimensional drawings

All dimensions in millimeters; general tolerance DIN ISO 2768 – mK

Dimensional drawing – cable outlet MiniCODER: Tangential left (L)

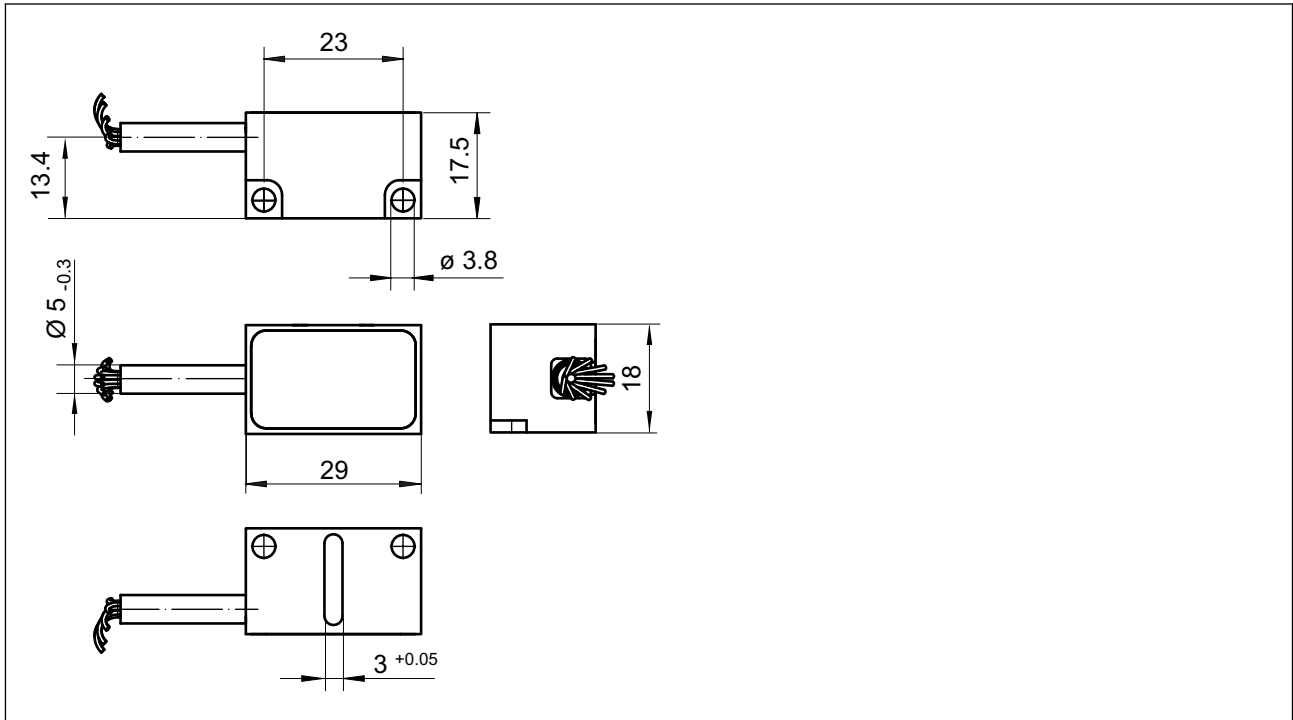

Hole pattern and installation dimensions

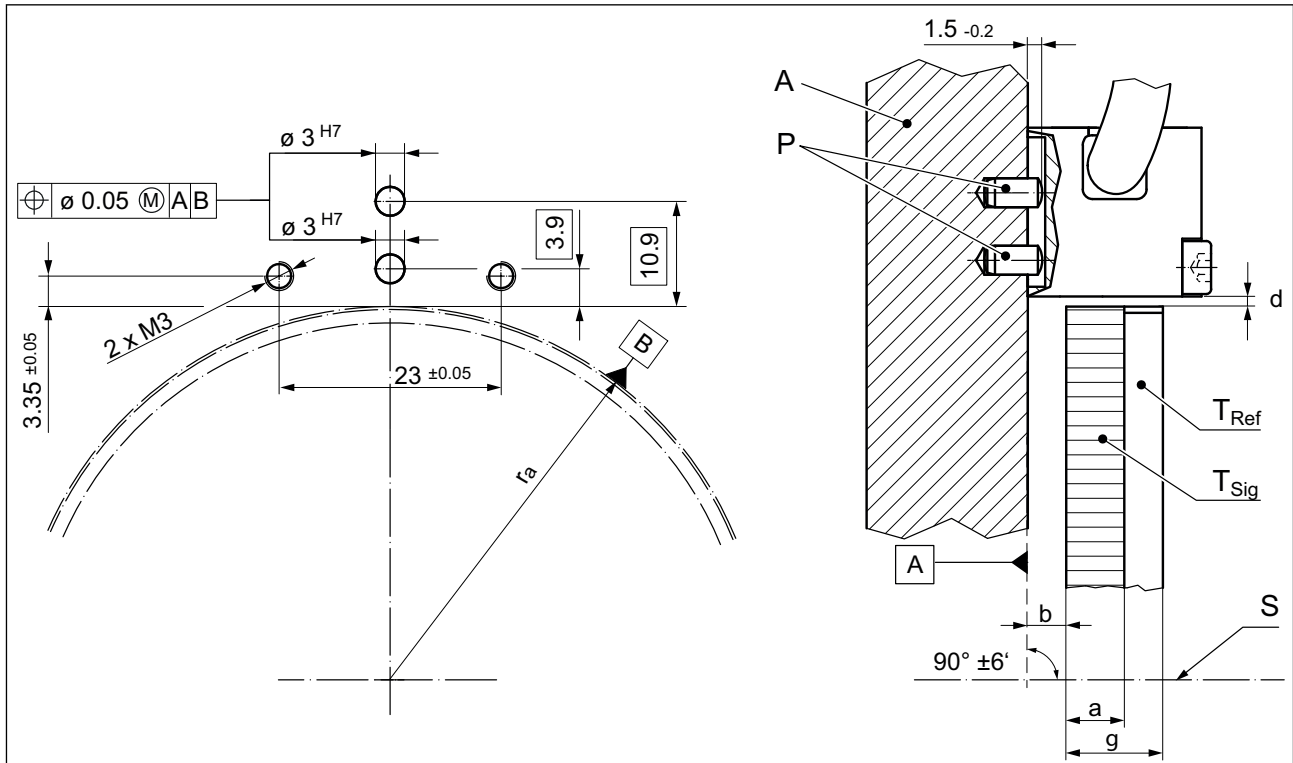

All dimensions in mm

- a Width of signal track: 6.0 mm
- b Distance from mounting surface to target wheel: depending on the target wheel geometry (for example, width of signal track)
- d Air gap: depending on the module (→ page 15)
- g Target wheel width
- $r_a = d_a/2$ (with d_a = target wheel tip circle diameter)
- A Mounting device
- P Positioning pins M3
- S Center line machine shaft/target wheel
- T_{Ref} Reference track (target wheel)
- T_{Sig} Signal track (target wheel)

Installation dimensions for standard target wheels

Dimension	ZAZ
g	10
$a_{1/2}$	6
a_N	4
b	4 ± 0.2

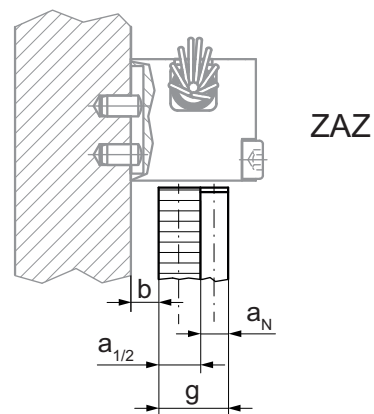

GEL 2449M

Type code

2449	Signal pattern	
	M	MHSSI (Mitsubishi High Speed Serial Interface) 2.5 Mbit
	Reference mark	
	Z	Tooth on tooth
	Optional extras	
	H	Configurable (resolution is independent of speed)
	P	Configurable (resolution is dependent on speed)
	Cable outlet MiniCODER	
	L	Tangential, cable outlet left
	Module ⁽¹⁾	
1	m= 1.0	
4	m= 0.4	
Connection type		
K	Flying lead	
Z	10-pin male connector (only available as cable length 100/120/200/250)	
Cable length L		
030	0.3 m	
050	0.5 m	
100	1.0 m	
120	1.2 m	
150	1.5 m	
200	2.0 m	
250	2.5 m	
Cable design for temperature sensor (2 m)		
-	Without temperature sensor cable	

i For MiniCODERs with optional extras **H** or **P** the resolution and the number of teeth can be configured with the testing and programming unit. You can find the factory settings on → [page 10](#). Other factory settings are available upon request.

i Technical information on MiniCODERs with other signal patterns is available online at www.lenord.com or can be requested from our support team (support@lenord.de).

⁽¹⁾ Other modules upon request

Your notes

This document and contents are the intellectual property of Lenord, Bauer & Co. GmbH. Without the written consent of Lenord, Bauer & Co. GmbH, the disclosure and forwarding to third parties as well as any exploitation of the contents, including the registration of intellectual property rights, is prohibited.



Lenord, Bauer & Co. GmbH	Lenord+Bauer Italia S.r.l.	Lenord+Bauer USA Inc.	Lenord+Bauer
Dohlenstraße 32	Via Gustavo Fara, 26	32000 Northwestern Highway	Automation Technology (Shanghai) Co.,Ltd.
46145 Oberhausen	20124 Milano	Suite 150	Block 42, Room 302, No.1000, Jinhai Road
Germany	Italy	Farmington Hills, MI 48334	201206 Shanghai
Phone +49 (0)208 9963-0	Phone +39 340 1047184	USA	China
www.lenord.de	www.lenord.com	Phone +1 248 446 7003	Phone +86 21 50398270
		www.lenord.com	www.lenord.cn