

General

- The measuring system comprises a MiniCODER and a precision target wheel for attachment to shafts.
- The MiniCODER contactlessly scans the precision target wheel using magneto-resistive sensors and provides the signals direction of rotation, rotational speed and position.

Features

- Output signal level
1 V_{pp} Differential signal (sin/cos) or TTL / RS422
- Square-wave differential reference signal (optional)
- Selection of interpolation factors to increase the number of pulses per revolution possible (TTL / RS422)
- Recording of temperature and rotational speed histogram and automatic calibration possible
- Frequency range from 0 to 200 kHz ⁽¹⁾ (sin/cos) or 0 to 500 kHz ⁽¹⁾ (TTL / RS422)
- Temperature range -40 °C to +120 °C
- Degree of protection IP 68
- **Safety integrated** certificate (signal pattern K)

Advantages

- Maintenance and wear-free
- Low temperature drift and high signal quality
- Highest immunity to interference due to fully screened metal housing
- Customized production of precision target wheels enables flexible integration into a wide variety of designs.

Field of application

- Machine tool engineering
 - HSC spindles (High Speed Cutting)
 - Screw spindles in vacuum pumps
 - Lathes, grinding and milling machines
- Test stands and motors (hybrid drives, torque motors)



MiniCODER with axial cable outlet

⁽¹⁾ At a cable capacitance of 5 nF

Right to technical changes and errors reserved.

Description

Design

The MiniCODERs are intended to be used for the contactless measurement of rotary and linear movements predominantly in machines, gears, motors or high-speed spindles. They are manufactured using the latest micro system technology and are fully encapsulated, as such they are particularly resistant to shocks and vibration.

Measuring system

The measuring system comprises a MiniCODER and a target wheel. The system does not need dedicated bearings for this task, as the target wheel is mounted directly on the machine shaft.

The measuring system operates contactlessly and is maintenance and electrical wear-free. It acquires the direction of rotation, rotational speed and position of the rotating machine shaft.

The target wheel is made of ferromagnetic material and is to be ordered separately.

The MiniCODER has a magnetic field that is changed by the rotating target wheel. The sensor acquires the change in the magnetic field and the integrated electronics convert this information into appropriate output signals.

External electronics can read the output signals and determine the direction of rotation, rotational speed and position of the machine shaft.

A defined air gap between the target wheel and MiniCODER is required for the contactless measurement. To make assembly easier, a corresponding distance gauge is included with the MiniCODER.

Reference mark

The MiniCODER can determine the position of a shaft by acquiring a reference mark.

The position is output as an square wave differential reference signal (reference track N).

The MiniCODER evaluates the following reference marks: Slot (**M**), lug (**N**), tooth (**Z**).

Module

Possible modules: 0.3 / 0.5 .



The MiniCODER must be ordered to suit the design of the reference mark and to suit the module of the target wheel.

Signal pattern

Signal pattern D, T

The output signals are two square-wave signals offset by 90° for the detection of direction (tracks 1 and 2) and their inverse signals.

The sequences of signals are dependent on the direction of rotation.

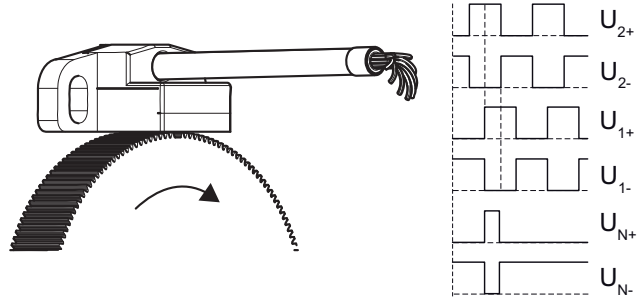

U_{N+} Reference signal (reference track N)



Signal pattern D: the MiniCODER acquires and saves the total operating time. This information can be read using the testing and programming unit GEL 211.

Signal pattern K

The output signals are two sinusoidal signals offset by 90° for the detection of direction (tracks 1 and 2) and their inverse signals.

The sequences of signals are dependent on the direction of rotation.

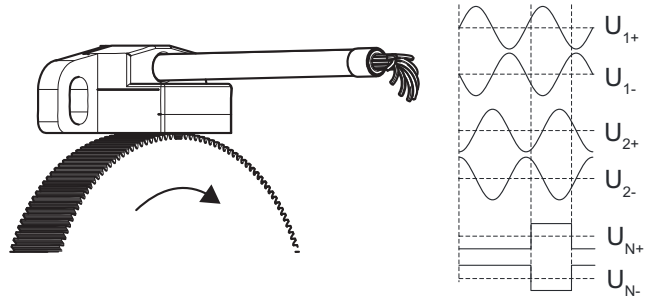

U_{N+} Reference signal (reference track N) optional

Cable outlet MiniCODER

The MiniCODER is available with the following cable outlets:

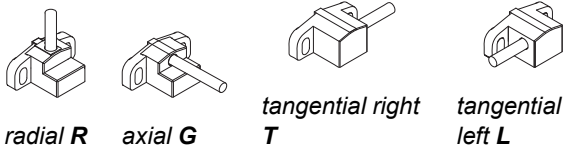

Optional extra for signal pattern D, T

Interpolation factor (1 / 2 / 4 / 8 / A / B / C / D / G)

The interpolation is undertaken directly in the MiniCODER. On the usage of a target wheel with 250 teeth and an interpolation factor of 20, the MiniCODER provides 5000 square-wave signals.

Optional extra for signal pattern K

Configurable (P)

Configuration of the MiniCODER via the connector

- Setting the sin/cos amplitudes without mechanical re-adjustment of the air gap
- Elimination of the offset and amplitude error for compensating mounting tolerances
- Definition of 7 rotational speed ranges for the activation of the rotational speed histogram in the MiniCODER
- Entry of a spindle serial number (allocation of the drive)

In addition, various items of data are saved in the MiniCODER and can be read using the GEL 211:

- Rotational speed histogram for the analysis of the drive's operating conditions
- Number of startups
- Minimum / maximum temperature in the MiniCODER
- Item number and serial number of the MiniCODER
- Total operating time and time since the last configuration



The MiniCODER can be adjusted, analysed and configured using the testing and programming unit GEL 211.

Not configurable, with Internal regulation (M)

The MiniCODER regulates fluctuations in the sin/cos amplitudes on changes in the air gap and temperature.

Not configurable (S)

Technical data

	GEL 2444_...3	GEL 2444_...5
Target wheel		
Module ⁽¹⁾	0.3	0.5
Width of the signal track	≥ 4.0 mm	
Material	Ferromagnetic steel	
Reference mark	Slot (M), lug (N), tooth (Z)	
Geometric data		
Centre distance between sensor elements (1/2 and N) c_2	6 mm	
Distance mounting surface to sensor element (1/2) c_1	9.5 mm	
Air gap permitted	0.15 mm ± 0.02 mm	0.20 mm ± 0.03 mm
Electrical data		
Supply voltage U_B	5 V DC ± 5%, polarity reversal protected, overvoltage protected	
Output signal level • GEL 2444D • GEL 2444K • GEL 2444T	TTL / RS422 1 V_{pp} Differential signal TTL / RS422	
Output signal • GEL 2444D • GEL 2444K • GEL 2444T	Two square-wave signals offset by 90° and their inverse signals, short-circuit-proof; option: reference signal Two sinusoidal signals offset by 90° and their inverse signals, short-circuit-proof; option: reference signal Two square-wave signals offset by 90° and their inverse signals, short-circuit-proof; option: reference signal	
Output frequency • GEL 2444D • GEL 2444K • GEL 2444T	0 to 500 kHz ⁽²⁾ 0 to 200 kHz ⁽²⁾ 0 to 500 kHz ⁽²⁾	
Power consumption without load	≤ 0.3 W	
Electromagnetic compatibility Electromagnetic emissions Electromagnetic immunity	DIN EN 61000-6-4:2011-09; DIN EN 61000-6-3:2011-09 DIN EN 61000-6-2:2006-03; DIN EN 61000-6-1:2007-10	
Dielectric strength	500 V, in accordance with DIN EN 60439-1	
Mechanical data		
Weight	30 g	
Housing material	Die cast zinc	
Working temperature range	-30 °C to +85 °C	
Operating and storage temperature range	-40 °C to +120 °C	
Degree of protection	IP 68	
Vibration resistance	200 m/s ² , in accordance with DIN EN 60068-2-6	
Shock resistance	2000 m/s ² , in accordance with DIN EN 60068-2-27	
MTTF FIT	5,000,000 h at 55 °C 204 10 ⁻⁹ h ⁻¹ at 55 °C	
Cable data (Cable version —)		
Number of cores x core cross-section	9 x 0.15 mm ²	
Cable diameter	5 mm	
Minimum bending radius	25 mm	
Maximum permitted cable length	100 m ⁽³⁾	

⁽¹⁾ Further modules upon request

⁽²⁾ At a cable capacitance of 5 nF

⁽³⁾ Pay attention to voltage drop on the supply cable



On the standard versions of the MiniCODER, the outer screen on the connection cable

- is connected to the MiniCODER housing
- is connected to the connector housing in metallised connectors
- is connected to a connector pin in plastic connectors

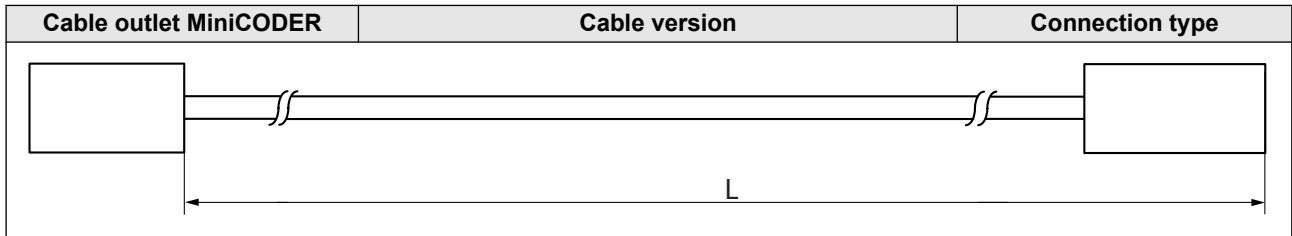

L = cable length

Cable outlets MiniCODER

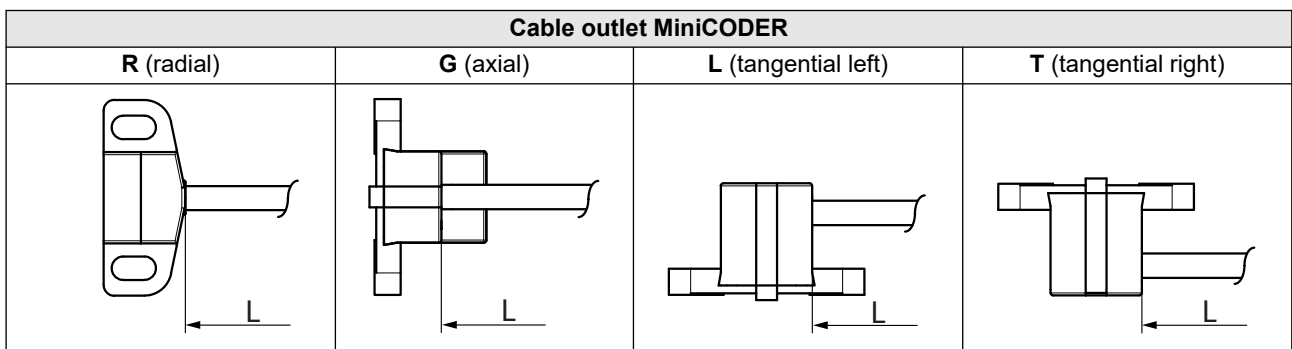





Cable versions for temperature sensor

Cable version	
— (without temperature sensor cable)	
M (2-core temperature sensor cable, 2 m long) Cable data — TEFLON cable $2 \times 0.14 \text{ mm}^2$ [26 AWG] — Outside diameter: 2.8 mm (± 0.1) — Minimum bending radius: 20 mm	
N (4-core temperature sensor cable, 2 m long) Cable data — ETFE cable $4 \times 0.14 \text{ mm}^2$ [26 AWG] — Outside diameter: 3.5 mm (± 0.2) — Minimum bending radius: 7 mm	
P (6-core temperature sensor cable, 2 m long) Cable data — ETFE cable $6 \times 0.14 \text{ mm}^2$ [26 AWG] — Outside diameter: 3.5 mm (± 0.2) — Minimum bending radius: 7 mm	

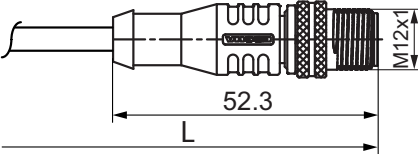
Connection

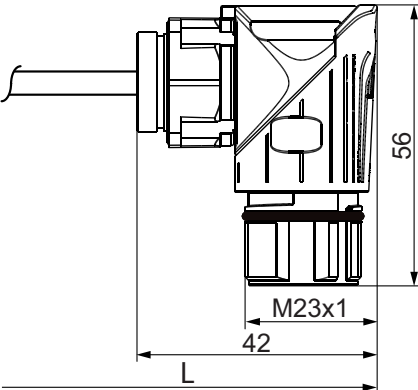
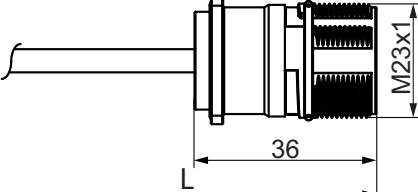
Connection types

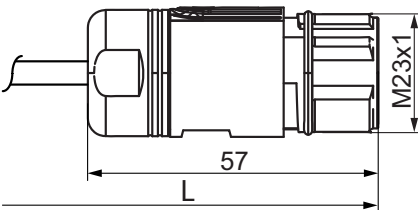
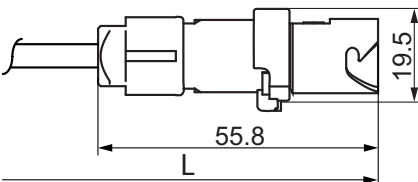
Connection type		Notes
J (12-pin male connector)		Not available with temperature sensor cable! Cable lengths available: 030 / 050 / 150 / 250 / 600
K¹⁾ (flying lead)		Not available with temperature sensor cable! Cable lengths available: 030 / 050 / 150 / 250 / 600
M (17-pin panel-mounting socket, angled, with pin contacts)		EMC screening, strain relief and sealing, IP 67 (connected)
N (17-pin panel-mounting socket with pin contacts)		EMC screening, strain relief and sealing, IP 67 (connected)
P (10-pin female connector)		Not available with temperature sensor cable! Cable length available to the centimetre!
U (12-pin coupling with pin contacts)		Not available with temperature sensor cable!
Z (10-pin male connector)		Not available with temperature sensor cable! Cable lengths available: 120 / 200 / 250

¹⁾ The delivery takes place with connected test plug from Lenord+Bauer.

All dimensions stated in millimeters

Pin layouts

Connection type J

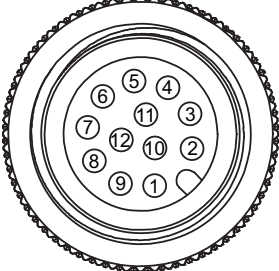
12-pin male connector (Mating view)	Pin	Signal / function	
	1	U_{1+}	Signal track 1
	2	U_{1-}	Inverse signal track 1
	3	U_{N+}	Signal reference track N
	4	0 V	GND
	5	U_B	+ 5 V supply voltage
	6	U_{2+}	Signal track 2
	7	U_{2-}	Inverse signal track 2
	8	U_{N-}	Inverse signal reference track N
	9	Not used	
	10	U_{Sense}	5 V Sense
	11	Not used	
	12	Not used	



External sense regulation is required with long power supply cables!

Connection type K

Flying lead (10-pin female connector, connection type P) (Mating view)	Pin	Core colour	Signal / function	
	1	red	U_B	+ 5 V supply voltage
	2	white	U_{1+}	Signal track 1
	3	brown	U_{1-}	Inverse signal track 1
	4	pink	U_{2+}	Signal track 2
	5	black	U_{2-}	Inverse signal track 2
	6	green	U_{Sense}	5 V Sense
	7	grey	U_{N+}	Signal reference track N
	8	yellow	U_{N-}	Inverse signal reference track N
	9	blue	0 V	GND
	10	Not used		



Reference mark –:

The yellow and the grey core carry power. Insulate the cores or connect the cores via resistors (> 2 k Ω) to U_B or 0 V.

Connection

Connection type M and N

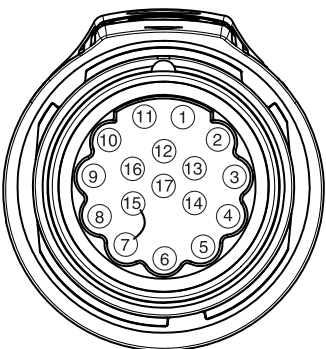
17-pin panel-mounting socket with pin contacts (Mating view)	Pin	Signal / function	
	1	U_{1+}	Signal track 1
	2	U_{1-}	Inverse signal track 1
	3	U_{N+}	Signal reference track N
	4 – 6	Not used	
	7	0 V	GND
	8	Not used	
	9	Not used	
	10	U_B	+ 5 V supply voltage
	11	U_{2+}	Signal track 2
	12	U_{2-}	Inverse signal track 2
	13	U_{N-}	Inverse signal reference track N
	14	Not used	
	15	0 V	GND (jumper pin 7)
	16	U_{Sense}	5 V Sense
	17	Not used	

Connection type M and N: Additional assignments on connection of a temperature sensor cable

17-pin panel-mounting socket with pin contacts	Core colour	Pin	Signal / function
2-core temperature sensor cable (Cable version M)	brown	8	Temp +
	blue	9	Temp –
4-core temperature sensor cable (Cable version N)	brown	8	Temp1 +
	white	9	Temp1 –
	green	4	Temp2 +
	pink	14	Temp2 –
6-core temperature sensor cable (Cable version P)	brown	8	Temp1 +
	white	9	Temp1 –
	grey	6	Temp2 +
	yellow	5	Temp2 –
	green	4	Temp3 +
	pink	14	Temp3 –

Connection type P

10-pin female connector (Mating view)	Pin	Signal / function	
	1	U_B	+ 5 V supply voltage
	2	U_{1+}	Signal track 1
	3	U_{1-}	Inverse signal track 1
	4	U_{2+}	Signal track 2
	5	U_{2-}	Inverse signal track 2
	6	U_{Sense}	5 V Sense
	7	U_{N+}	Signal reference track N
	8	U_{N-}	Inverse signal reference track N
	9	0 V	GND
	10	Not used	

Connection type U

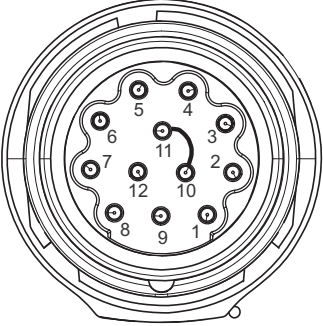
12-pin coupling with pin contacts (Mating view)	Pin	Signal / function	
	1	U_{2-}	Inverse signal track 2
	2	U_{Sense}	5 V Sense
	3	U_{N+}	Signal reference track N
	4	U_{N-}	Inverse signal reference track N
	5	U_{1+}	Signal track 1
	6	U_{1-}	Inverse signal track 1
	7	Not used	
	8	U_{2+}	Signal track 2
	9	Not used	
	10	0 V	GND
	11	0 V	GND (jumper pin 10)
	12	U_B	+ 5 V supply voltage

Connection

Connection type Z

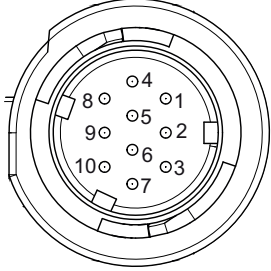
10-pin male connector (Mating view)	Pin	Signal / function	
	1	U_{2+}	Signal track 2
	2	U_{2-}	Inverse signal track 2
	3	Screen	
	4	U_B	+ 5 V supply voltage
	5	U_{1+}	Signal track 1
	6	U_{1-}	Inverse signal track 1
	7	0 V GND	
	8	U_{N+}	Signal reference track N
	9	U_{N-}	Inverse signal reference track N
	10	Not used	



Sense regulation not possible!

Dimensional drawings

Dimensional drawing GEL 2444 with cable outlet MiniCODER (G) — axial

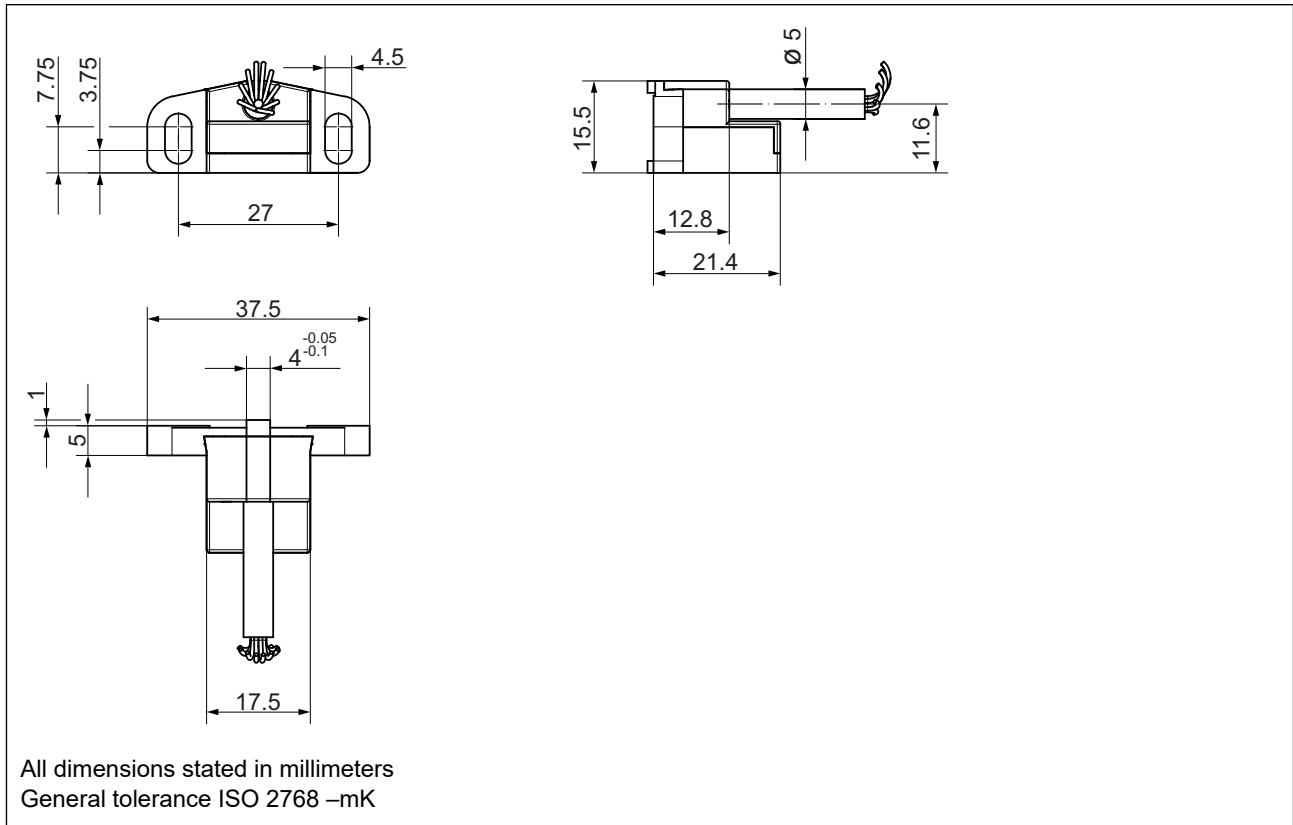

Dimensional drawing GEL 2444 with cable outlet MiniCODER (L) — tangential left

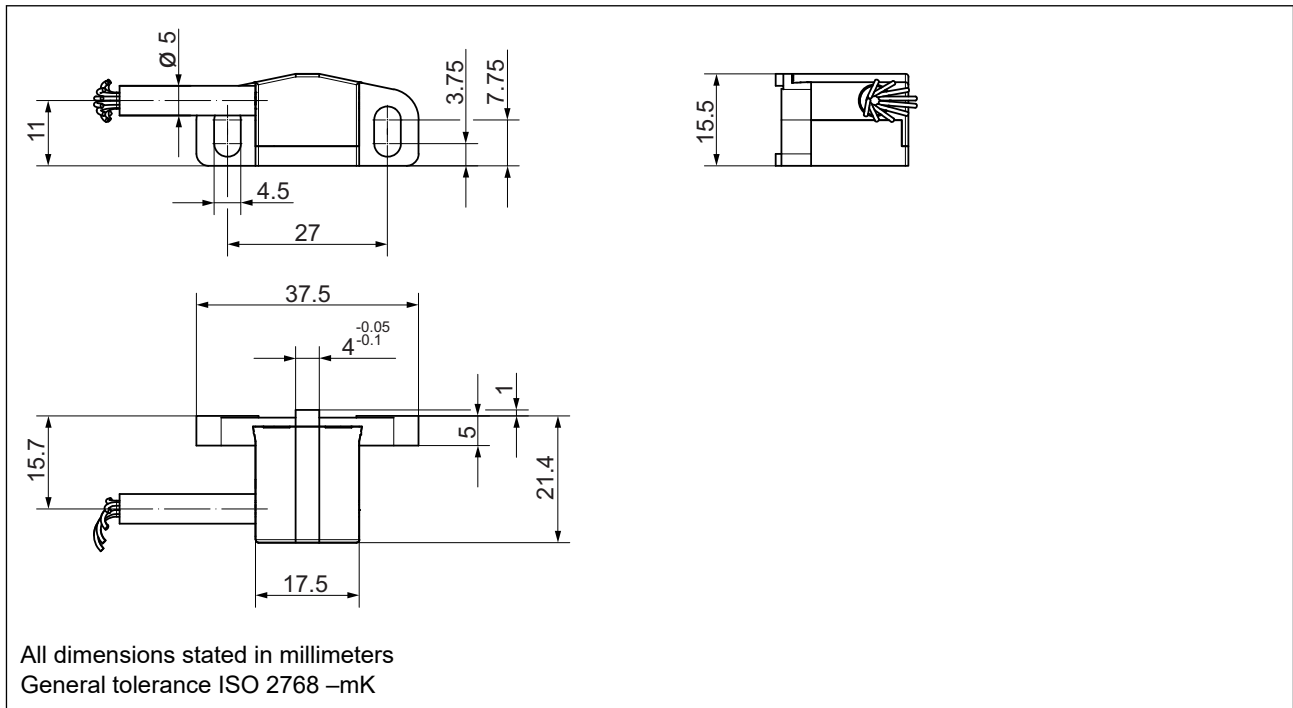

Dimensional drawings

Dimensional drawing GEL 2444 with cable outlet MiniCODER (R) — radial

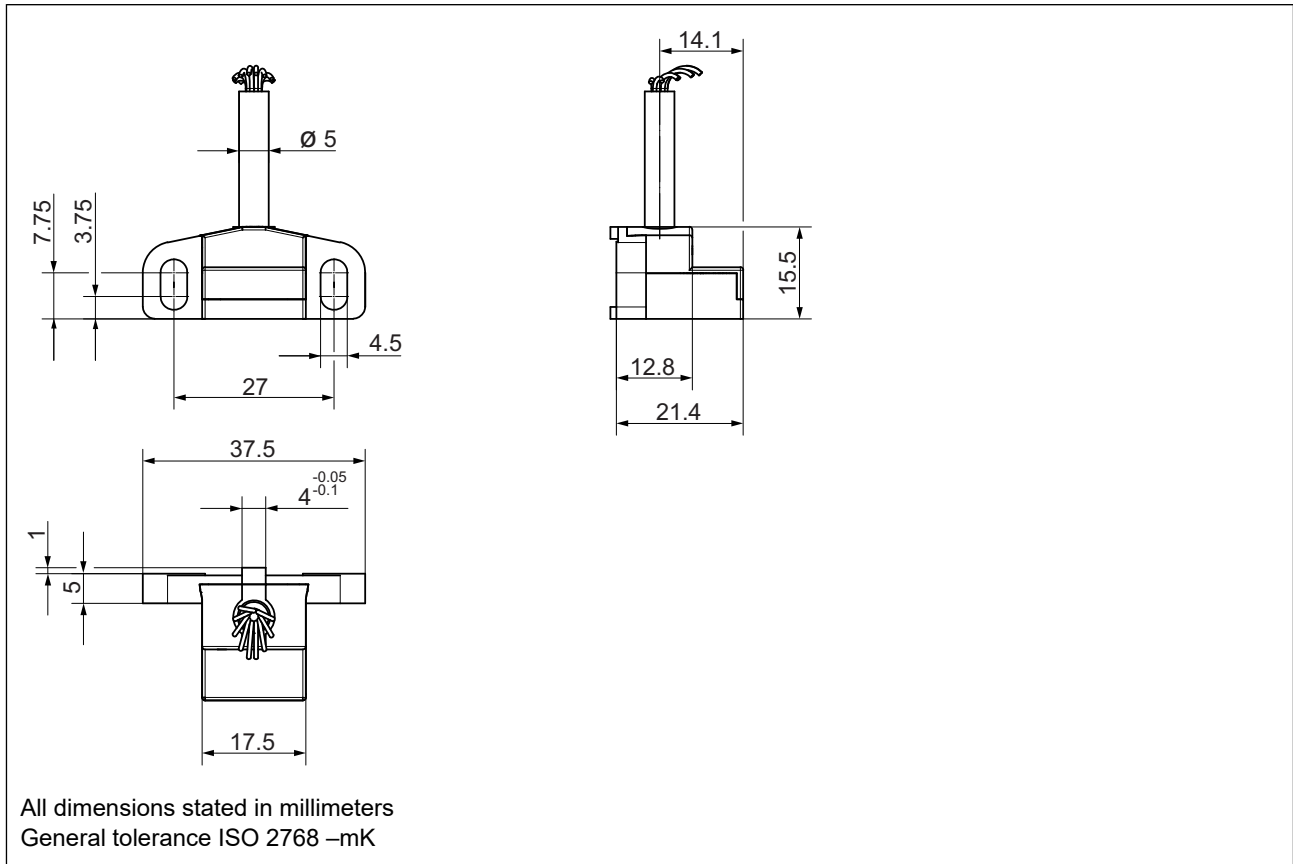

Dimensional drawing GEL 2444 with cable outlet MiniCODER (T) — tangential right

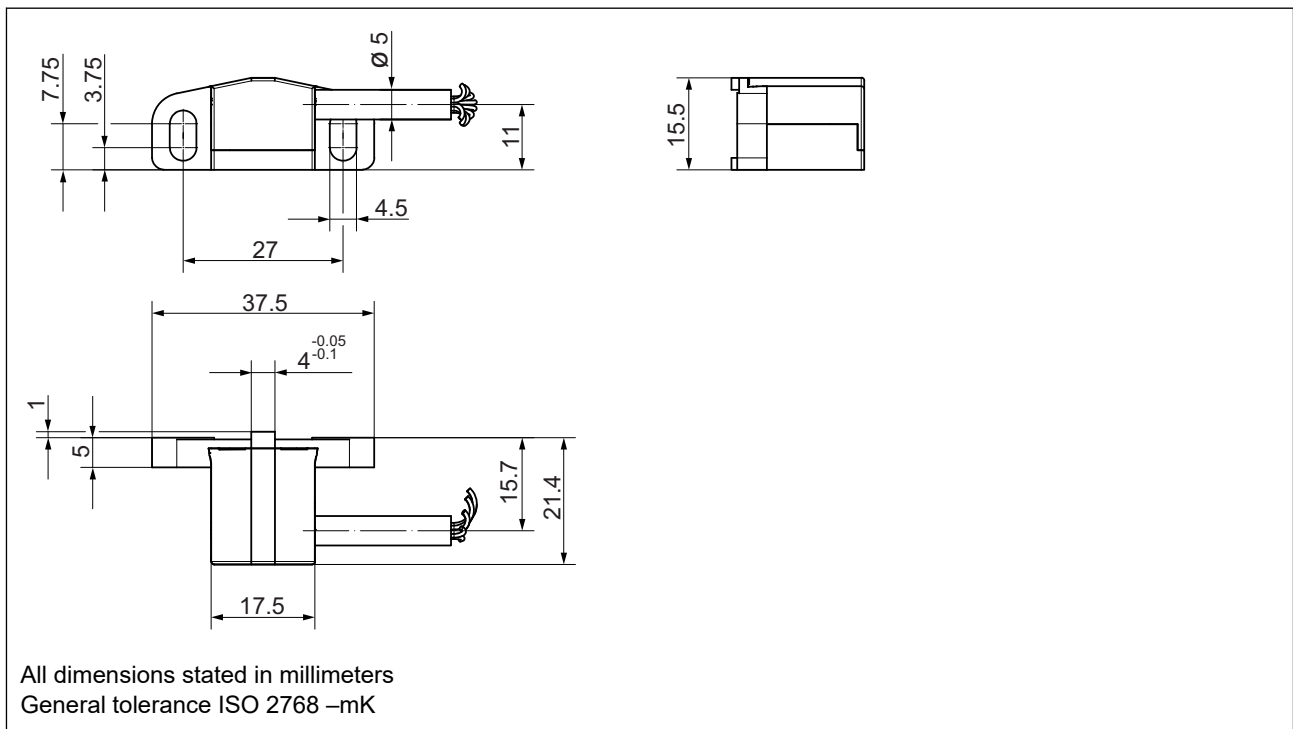

Hole pattern and installation dimensions, air gap table

Hole pattern and installation dimensions

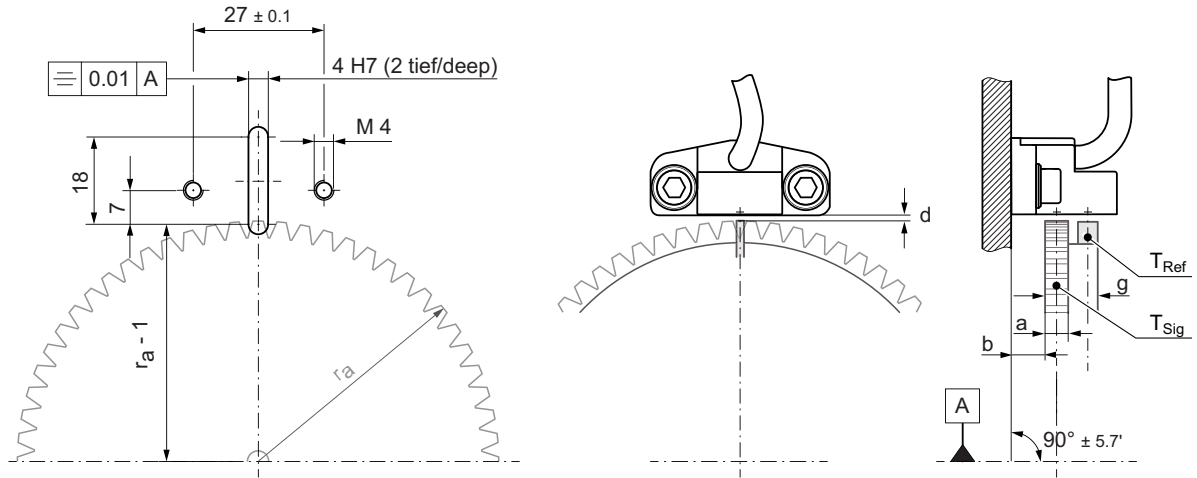

All dimensions stated in mm

- a Width of the signal track: ≥ 4.0 mm
- b Mounting surface to tooth wheel distance: dependent on the geometry of the target wheel (for example, width of the signal track)
- d Air gap: dependent on the module (see air gap table)
- g Width of the target wheel
- $r_a = d_a/2$ (with d_a = Outside diameter of the tooth wheel)
- T_{Ref} Reference track
- T_{Sig} Signal track

Installation dimensions for standard target wheels

Dimension	ZA-	ZAN	ZAZ
g	4	10	10
$a_{1/2}$	4	4	6
a_N	-	4	4
b	7.5 ± 0.5	7.5 ± 0.5	7.5 ± 0.5

Position of the sensor elements:
 $c_1 = 9.5$ mm; $c_2 = 6$ mm

All dimensions stated in millimeters
 General tolerance ISO 2768 -mK

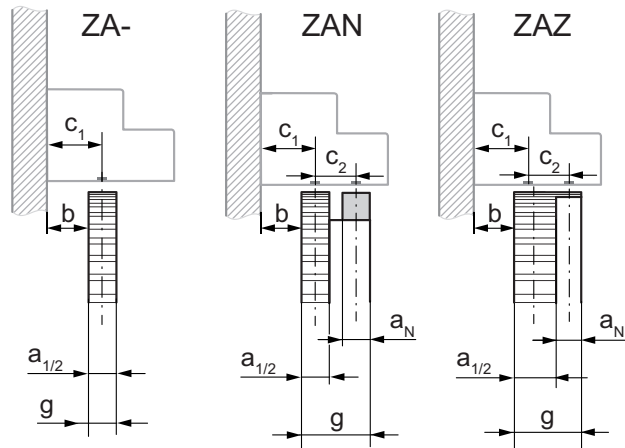

Air gap table

Type	Module	Air gap d , preset measure \pm distance tolerance
3	0.3	0.15 mm \pm 0.02 mm
5	0.5	0.20 mm \pm 0.03 mm

To make assembly easier, a corresponding distance gauge is included with the MiniCODER.

Type code

Type code GEL 2444

2444	Signal pattern	
	D	Square-wave signals TTL / RS422, rotational speed histogram
	K	Sin/cos signals 1 V _{pp}
	T	Square-wave signals TTL / RS422
	Reference mark	
	–	None
	M	Slot
	N	Lug
	Z	Tooth on tooth
	Optional extras	
1	Interpolation factor 1	
2	Interpolation factor 2	
4	Interpolation factor 4	
8	Interpolation factor 8	
A	Interpolation factor 10	
B	Interpolation factor 12	
C	Interpolation factor 16	
D	Interpolation factor 20	
G	Interpolation factor 32	
M	Not configurable, with internal amplitude regulation	
P	Configurable	
S	Not configurable	
Cable outlet MiniCODER		
G	Axial	
L	Tangential, cable outlet left	
R	Radial	
T	Tangential, cable outlet right	
Module ⁽¹⁾		
3	0.3	
5	0.5	
Connection type		
J	12-pin male connector (only cable lengths 030 / 050 / 150 / 250 / 600 available)	
K	Flying lead ⁽²⁾ (only cable length 030 / 050 / 150 / 250 / 600 available)	
M	17-pin panel-mounting socket, angled, with pin contacts	
N	17-pin panel-mounting socket with pin contacts	
P	Test connector (10-pin female connector), cable length can be selected to the centimetre	
U	12-pin coupling with pin contacts	
Z	10-pin male connector (only cable length 120 / 200 / 250 available)	
Cable length L⁽³⁾		
030	0.3 m	
050	0.5 m	
120	1.2 m	
150	1.5 m	
200	2.0 m	
250	2.5 m	
600	6.0 m	
Cable version for temperature sensor (2 m)		
–	Without cable for temperature sensor	
M	With 2-core temperature sensor cable (only for connection type M, N)	
N	With 4-core temperature sensor cable (only for connection type M, N)	
P	With 6-core temperature sensor cable (only for connection type M, N)	



You will find MiniCODERs with digital interfaces in the Technical information GEL 244x Digital interfaces (D-02T-244X-S).

⁽¹⁾ Further modules upon request

⁽²⁾ The delivery takes place with connected test plug from Lenord+Bauer.

⁽³⁾ Other cable lengths upon request; maximum cable length: 6.0 m

Restrictions in the type code

Signal pattern, optional extras and reference mark

Signal pattern	Reference mark	Optional extras	Note
D	M / N / Z	1 / 2 / 4 / 8 / A / B / C / D / G	Interpolation factor
K	— / M / N / Z	M	Not configurable, with internal amplitude regulation
	— / M / N / Z	S	Not configurable
	— / M / N / Z	P	parametrierbar
T	— / M / N / Z	1 / 2 / 4 / 8 / A / B / C / D / G	Interpolation factor

Overview of functions GEL 211

GEL 2444			Functions GEL 211		
Signal pattern	Reference mark	Optional extras	Signal optimisation	Signal check	Rotational speed histogram
K	M / N / Z	P	Yes	Yes	Yes
K	—	P	Yes	Yes	No
K	— / M / N / Z	M / S	No	Yes	No
T	— / M / N / Z	1 / 2 / 4 / 8 / A / B / C / D / G	No	No	No
D	M / N / Z	1 / 2 / 4 / 8 / A / B / C / D / G	No	No	Yes

Use in safety applications

Fault detection has a major influence on the availability of safety functions. This task must be realised by the control system, as fault detection is not integrated into the sensor.



Safety of the overall system

The assessment of the safety of the drive train and the machine can only be undertaken by the machine manufacturer taking account the relevant directives, standards and safety regulations.

MTTF_d⁽¹⁾

For simplicity it is assumed that only 50 % of the hardware failures on electronic components are hazardous failures. For MTTF_d figures it is therefore typically possible to assume twice the MTTF figure⁽²⁾ (sources: EN ISO 13849-1:2008 (D); Annex C, section 5.2 Semiconductors; EN 61800-5-2:2007, Annex B, section 3.1.3 Anteil sicherer Ausfälle (Portion of safe failures)). The expected operating temperature must be taken into account in this assumption.

PFH_d⁽³⁾

The performance level and SIL level do not relate to the reliability of sub-components but to the availability of safety functions. The MTTF_d figures for the sensors are used in these calculations.

Characteristics as a function of the temperature

Operating temperature [°C]	FIT [10 ⁻⁹ h ⁻¹] ⁽⁴⁾	MTTF [h] ⁽²⁾
85	1611	620732
75	805	1242236
65	402	2487562
55	204	5000000
45	105	9523810

Safety Integrated

MiniCODERs with sin/cos signals (signal pattern **K**) have been checked according to Safety Integrated by the IFA in conjunction with Siemens Sinumerik control systems.

IFA assessment

(IFA test report no. 2013 23874):

"The sensor is suitable for providing two independent items of speed information. Due to the fault detection in the Sinumerik control systems, it is only necessary to use one sensor for safety applications."

Control systems from other manufacturers

For control systems from other manufacturers with a safety function, fault detection must be undertaken in the control system as in the Sinumerik:

- Faults in the sensor function are detected in the downstream control system by monitoring the differential sin/cos signals. For this purpose the amplitudes, the frequency, the offset or the phase on the sin/cos signals should be checked for plausibility.
- Mechanical slip or detachment of the target wheel from the shaft in operation or at standstill should, for example, be excluded by a connection with a shaped fit.

Some measures for fault detection by control systems on the usage of sinusoidal sensor signals are listed in DIN EN 61800-5-2 Table 16 for electrical power drive systems with adjustable rotational speed.

(1) Mean time to failure "dangerous"

(2) Mean time to failure

(3) Probability of dangerous failure per hour

(4) Failure in time; i.e. failures per 10⁹ hours

Explanations about the target wheel

Target wheels

For the measurement of rotary movements, MiniCODERs form a unit together with target wheels. The target wheel size and the related diameter depend directly on the module and the number of teeth.

Standard target wheels

Standard target wheels are available on short delivery times from stock. For specifications and designs see "Technical information ZAx / ZFx (DS51-ZAx/ZFx)".

Custom target wheels

Custom target wheels are manufactured individually to customer requirements. Please send us a design drawing of your target wheel to info@lenord.de.

Reference marks

The MiniCODER can detect reference marks in the form of a slot, lug or tooth. The acquired reference signal can be used for referencing the position. This feature is necessary, for example, to change automatically a tool in a milling spindle or grinding spindle.

The selection of the reference mark is defined by the size and rotational speed of the target wheel used, as both parameters have an effect on the forces acting on the reference mark. In case of new designs we recommend the usage of a target wheel with reference mark variant "Z".

Reference mark N – lug

A metal lug integrated into the target wheel and that is positioned exactly between two teeth is detected. The lug must be made of ferromagnetic material and must not protrude beyond the outside diameter of the target wheel. Due to the forces acting on the reference lug, this variant is only allowed to be used in a very limited speed range.

Reference mark M – slot

The MiniCODER detects a reference slot between two teeth. This target wheel is made up of two pieces for technical reasons.

Reference mark Z – tooth on tooth

These target wheels are made from one piece.

Module

The module is a tooth parameter for target wheels and describes the relationship between the number of teeth and the diameter of the target wheel. Given the same number of teeth, the smaller the module, the smaller the outside diameter.



The MiniCODER must be ordered to suit the design of the reference mark and to suit the module of the target wheel.

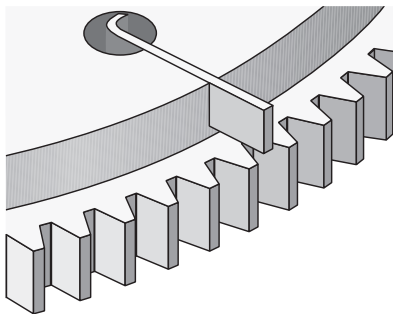

N = Reference mark – lug

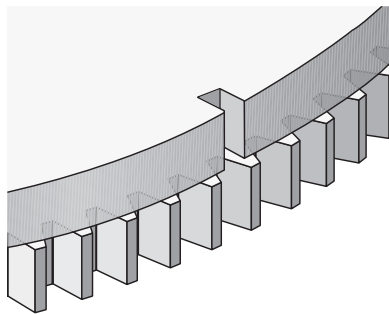

M = Reference mark – slot

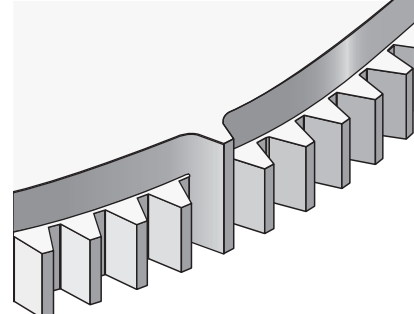

Z = Reference mark – tooth
Standard target wheel

Accessories

Testing and programming unit



- Testing Lenord+Bauer sensors with sin/cos output 1 V_{pp}, for example, MiniCODER
- Transmitting the data via WLAN or Ethernet to mobile terminal devices (for example, tablet, PC)
- Display of the data in a web browser, independent of the operating system

- Used for checking the signals for compliance with adjustable tolerance limits
 - sin/cos signals (amplitude, offset, phase offset)
 - Reference signal (amplitude, offset, position and width)
 - Target wheel (damage, concentricity, quality of the teeth)
- Defining and saving different tolerance limits

- Used for the configuration of the MiniCODER
 - Automatic calibration of the sin/cos signals
 - Configuring/reading the operating hours counter (rotational speed histogram)
 - Saving the 7 configured speed ranges of the operating hours counter in one record; Possible to save several records in the GEL 211

Accessories ⁽¹⁾

Item number:	Identifier:
PK211C-244XK-E	Configuration kit (Ethernet), consisting of: <ul style="list-style-type: none"> ▪ Testing and programming unit GEL 211CS04E2M ▪ Sensor connection cable GG211 ▪ Power supply unit 5 V, ZB211CB ▪ Operating instructions D-71B-211CS0 ▪ Case, XW1303
PK211C-244XK-W	Configuration kit (WLAN), consisting of: <ul style="list-style-type: none"> ▪ Testing and programming unit GEL 211CS04W2M ▪ Sensor connection cable GG211 ▪ Power supply unit 5 V, ZB211CB ▪ Operating instructions D-71B-211CS0 ▪ Case, XW1303
GG211-JAE	Adapter cable GEL 211 for MiniCODER with connection type Z
GG211-12POL-M12	Adapter cable GEL 211 for MiniCODER with connection type J
GG211-12POL-M23	Adapter cable GEL 211 for MiniCODER with connection type U
GG211-17POL-M23	Adapter cable GEL 211 for the connection of the Precision-Box GEL SDA10

⁽¹⁾ Sensors with signal pattern **T** cannot be analysed using the testing and programming unit.

Information about the square wave reference signal

A control system evaluates the zero transitions on the rising and falling edge of the reference signal to determine the width and position of the reference signal.

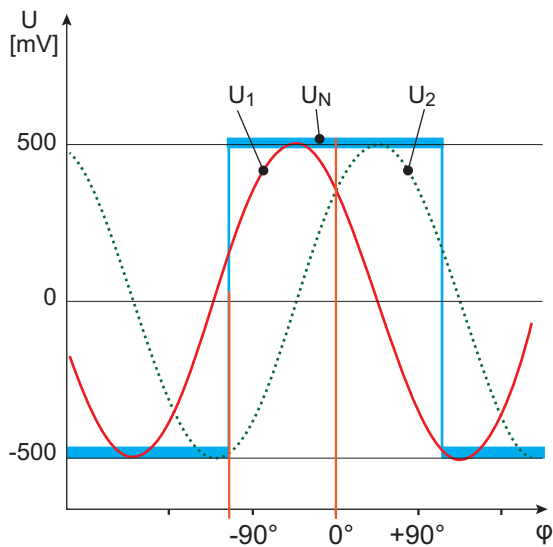

$$\begin{aligned}U_1 &= U_{1+} - U_{1-} \\U_2 &= U_{2+} - U_{2-} \\U_N &= U_{N+} - U_{N-}\end{aligned}$$

The square wave reference signal is dependent on

- the width and shape of the reference mark
- the position of the reference mark in relation to the teeth on the signal track
- the module of the precision target wheel

The following applies for the square wave reference signal:

- The amplitude of the reference signal is independent of the air gap and in the ideal case set to +500 mV.
- The offset level in relation to the quiescent voltage is fixed at -500 mV to provide a large signal to noise ratio.

The reference signal correspond to the common specifications for reference signals on the usage of 1 V_{pp} interface.



If you have any questions, please contact our Service department.
You will find information on our Service department on our homepage www.lenord.com.

This document and contents are the intellectual property of Lenord, Bauer & Co. GmbH. Without the written consent of Lenord, Bauer & Co. GmbH, the disclosure and forwarding to third parties as well as any exploitation of the contents, including the registration of intellectual property rights, is prohibited.



Lenord, Bauer & Co. GmbH	Lenord+Bauer Italia S.r.l.	Lenord+Bauer USA Inc.	Lenord+Bauer
Dohlenstraße 32	Via Gustavo Fara, 26	32000 Northwestern Highway	Automation Technology (Shanghai) Co.,Ltd.
46145 Oberhausen	20124 Milano	Suite 150	Block 42, Room 302, No.1000, Jinhai Road
Germany	Italy	Farmington Hills, MI 48334	201206 Shanghai
Phone +49 (0)208 9963-0	Phone +39 340 1047184	USA	China
www.lenord.de	www.lenord.com	Phone +1 248 446 7003	Phone +86 21 50398270
		www.lenord.com	www.lenord.cn