

# Precise encoder kit MiniCoder GEL 244

High resolution, frequency range 0 ... 200 kHz,  
with reference signal



## Technical Information

Version 05.01

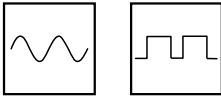

### General Information

Contactless measurement of rotation motions

- toothed wheel as measure with module 0.3 or module 0.5
- high EMC and immunity to electromagnetic disturbance by the internal structure and a consistent screening
- very high protection class IP 68 and chemical resistance
- can be used under very harsh conditions
- very high temperature range -40 °C ... +120 °C
- certificate „safety integrated“

### Fields of application

- C-axle operation
- high-speed spindle
- mechanical - and motors engineering
- special mechanical engineering

### Measuring principle

- integrated magnetoresistors for the contactless scanning of a toothed wheel
- internal enhancement of the magnetoresistor signals and temperature compensation

### Output signals

- output as sine- or square wave signal
- frequency range from zero to max. 200 kHz
- reverse battery protection of supply voltage
- short-circuit-proof outputs
- waveforms:
  - two signals dephased by 90° for detection control
  - sine- or square wave signal
  - all signals are inverted in addition
  - option: reference signal

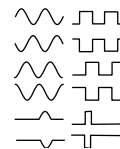

### Design

- temperature-resistant plastic housing
- completely sealed
- cable outlet

# Technical data

## Technical data GEL 244



supply voltage $U_B$	5 V DC $\pm$ 5%, reverse battery protected
power consumption without load	$\leq$ 1 W
permissible air gap	<b>0.10 mm <math>\pm</math> 0.02 mm at module 0.3</b> <b>0.15 mm <math>\pm</math> 0.03 mm at module 0.5</b>
measuring toothed-wheel breadth	min. 4.0 mm
material measuring toothed-wheel	ferromagnetic steel
max. permissible cable length	100 m (take into account the voltage drop in the supply cable)
operating temperature range	-30°C ... +85°C
operating- and storage temperature range	-40°C ... +120°C
protection class	IP 68
electromagnetic compatibility	EN 50081-1 and 2; EN 50082-1 and 2
insulation strength	500 V
vibration protection (EN 50155)	200 m/s <sup>2</sup>
shock protection ( IEC 68-T2-27)	2000 m/s <sup>2</sup>
weight	10 g
housing material	polyphenylene sulfide (PPS) glassfibre reinforced
connection cable	9-core cable, cross section 0.14 mm <sup>2</sup>

The declared technical data apply to the operating temperature range.

## Specific technical data GEL 244 K/KM/KN (sine-wave output)



output level	500 mV <sub>pp</sub> corresponds to 1 V <sub>pp</sub> as difference signals
output signals	two sine-wave signals, by 90° out of phase, and their inverse signal short-circuit-proof, option: reference pulse
output frequency	0 ... 200 kHz for C <sub>L</sub> = 5 nF
offset (static)	$\leq  60 \text{ mV} $
amplitude tolerance	-20 ... +10 %
amplitude ratio $U_A/U_B$	0.9 ... 1.1

## Specific technical data GEL 244 T/TN (square wave output)



output signals	two square-wave signals, by 90° out of phase, and their inverse signal short-circuit-proof, option: reference pulse
outputs	TTL-, RS 422- and RS 485 compatible

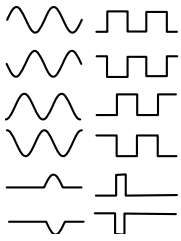

# Pin layouts, Dimensions

## Sine-wave output signals K, KM, KN

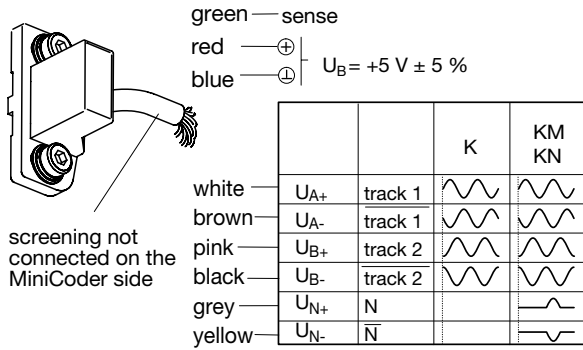

## Square-wave output signals T, TN

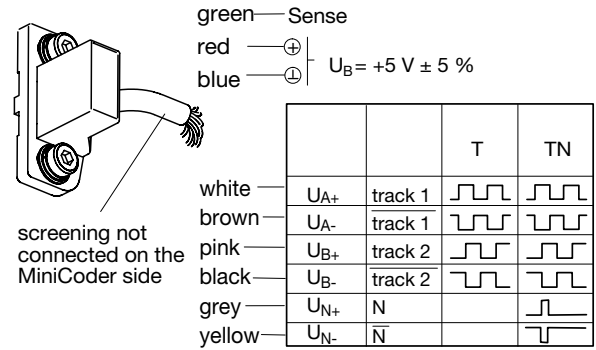

## Sine-wave output signals (ideal case)

$\hat{u} = 250 \text{ mV}$   
 $u_{N+}, u_{N-} = \text{reference signal}$

$$\left. \begin{aligned} u_{A+}(t) &= U_B/2 + \hat{u} \cdot \sin(2\pi f_e \cdot t) \\ u_{A-}(t) &= U_B/2 - \hat{u} \cdot \sin(2\pi f_e \cdot t) \\ u_{B+}(t) &= U_B/2 \mp \hat{u} \cdot \cos(2\pi f_e \cdot t) \\ u_{B-}(t) &= U_B/2 \pm \hat{u} \cdot \cos(2\pi f_e \cdot t) \end{aligned} \right\}$$

\*) depending on the sense of rotation

its difference comes up to a voltage of  $1 V_{pp}$   
 The indicated amplitude is valid in case of rated air gap.

## Dimensions (mm)

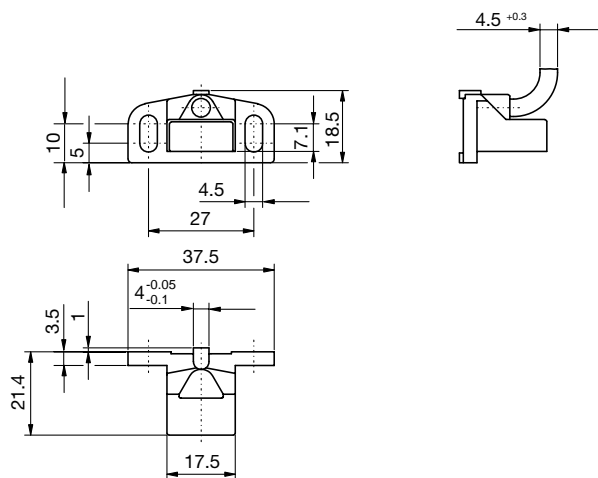

## Boring and milling sketch

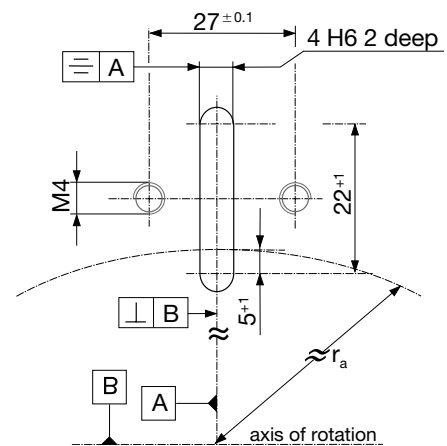

$r_a = d_a/2$ ;  $d_a = \text{OD of toothed wheel}$

# Type code

244	--	1	-	-	Description
					<p><b>Module</b></p> <p><b>3</b> module 0.3</p> <p><b>5</b> module 0.5</p> <p><b>Cable connection</b></p> <p><b>G</b> cable length 30 cm</p> <p><b>S</b> customize cable connection on request</p> <p><b>Signal pattern</b></p> <p><b>K-</b> sine-wave signal pattern</p> <p><b>KN</b> sine-wave signal pattern with analogue reference signal (flag)</p> <p><b>KM</b> sine-wave signal pattern with analogue reference signal (groove)</p> <p><b>T-</b> square-wave signal pattern 5 V</p> <p><b>TN</b> square-wave signal pattern 5 V with digital reference signal 5 V</p>

## Assembly instructions

### Assembly

- The MiniCoder must be **symmetrically** adjusted and centered to the toothed wheel. Dissymmetry causes measuring errors.
- M4 screws, washers and lock washers should be used for fastening. **The torque should be 60 Ncm.**
- Set the **air gap** in accordance with the table using the gap gauge which you will find attached to the MiniCoder serving as a transport protection.
- Avoid any mechanical contact between the

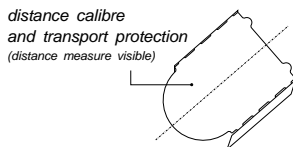

toothed wheel and the 0.1 mm protective layer of the scanning system. **Scratches** on the protective layer may cause the **total failure** of the MiniCoder.

- Ferromagnetic chips influence the result of measurement. If necessary, use a collecting magnet.
- Do not damage the surface of the toothing. Do not allow any mechanical components to run on the surface of the toothing.

### Disassembly

Prior to dismantling the sensor, i. e. before releasing the screws, you must slip on the distance gauge to avoid the sensor being pulled onto the toothed wheel by the magnet and thus being damaged.

### Non-Lenord+Bauer supplied toothed wheels

- If you make your own toothed wheels, please observe the following:
  - Provide an involute toothing as per DIN 867.
  - You can only use toothed wheels with module 0.3 or module 0.5.
  - Bear in mind that mechanical inaccuracies of tooth period, tooth shape and true running do affect the accuracy of the system.

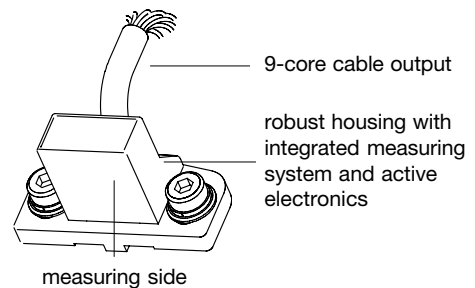

- The reference mark must be made of ferromagnetic material and must not jut out over the addendum circle of the toothed wheel.
- If the toothed wheel has a (slight) eccentricity, the MiniCoder must be adjusted in such a way that the air gap tolerance is observed in case of the smallest distance between the MiniCoder and the toothed wheel.

### Assembly drawing

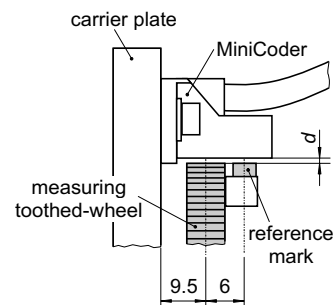

module	air gap d adjustment dimension	distance tolerance
0.3	0.10	± 0.02 mm
0.5	0.15	± 0.03 mm

# Adjustment

## Offset

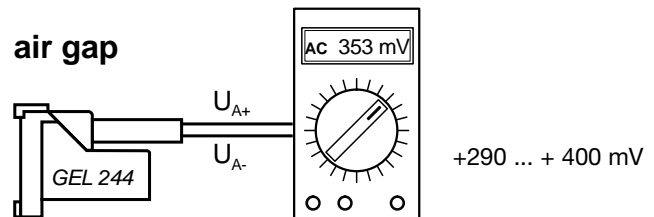
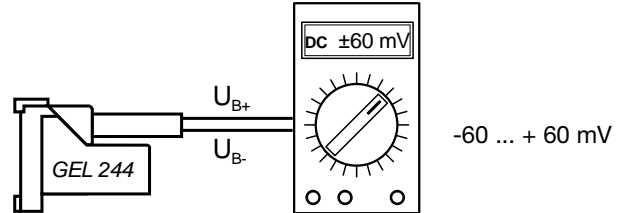
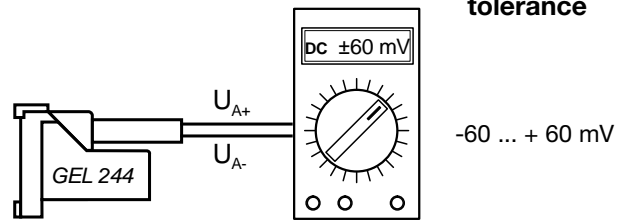
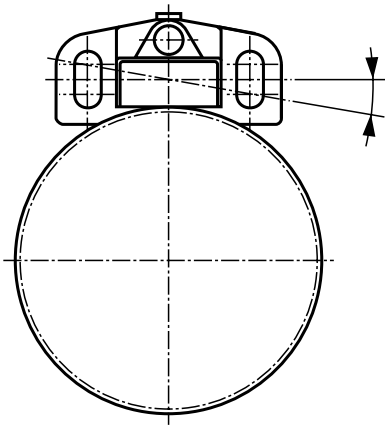

## Phase

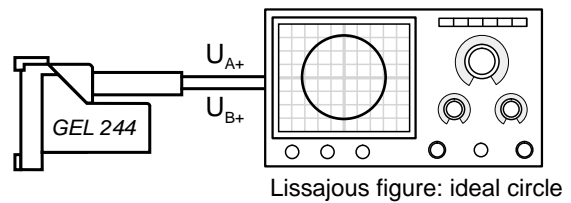
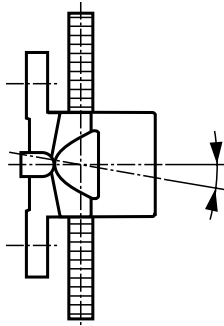

## Amplitude

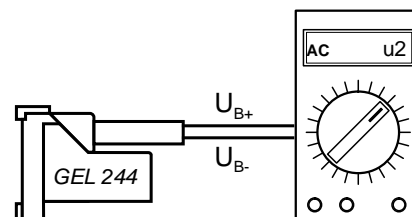
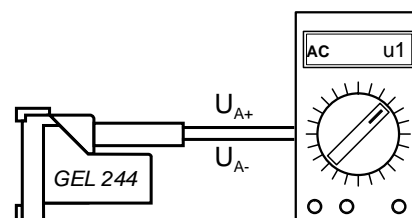
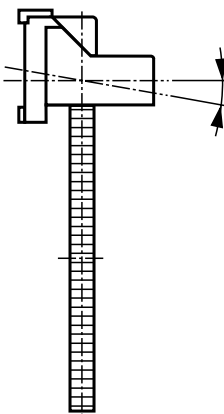

$$\frac{u1}{u2} = 0.9 \dots 1.1$$

**Fax: +49 (0)2 08 / 67 62 92**

**Transmitter**

Name: ..... Contact/person in charge: .....

Street: ..... .....

Postal code/City: ..... .....

Phone: ..... Phone: .....

Fax: ..... Fax: .....

**Measuring toothed-wheel**

Measuring toothed-wheel types  A  B  C

AN

BN

CN

tooth number **z** .....

module **m**  0.3  0.5

∅ OD **da**=  $m(z+2)$  ..... mm

∅ ID **di** + tolerance zone ..... mm

∅ shaft **dw** + tolerance field ..... mm

width of **zb** ( $\geq 4$  mm) ..... mm

toothed face

∅ right **dr** ..... mm

( $\leq da - 29$  mm with zero flag)

∅ left **dl** ..... mm

collar right **br** ..... mm

collar left **bl** ..... mm

reference mark (flag)  yes  no

reference mark (groove)  yes  no

**Hole circle/bores for mounting**

thread bore  through bore  cylindrical counterbore  conical counterbore

∅ hole circle **lk** ..... mm

∅ bore/thread **b** ..... mm

∅ bore **b<sub>1</sub>** ..... mm

depth **t** ..... mm

number of bores ..... pc. no.

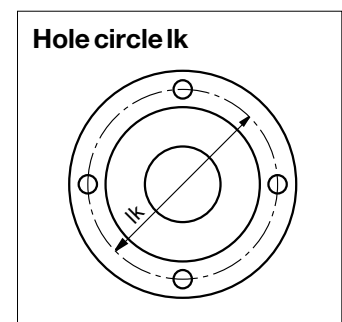

Additional remarks

.....

.....

.....

.....

.....

.....

.....

.....



# Standard measuring toothed-wheel

## Measuring toothed-wheel

For detecting rotary movements Minicoders and toothed-wheel form a unit. The size of the measuring toothed-wheel and, consequently, its diameter directly depends on the module and the tooth number, i. e.:

$$z = (d_a / m) - 2$$

$$d_a = m \cdot (z+2)$$

Standard measuring toothed-wheels (see chart) can be supplied short-term ex works.

## Chart standard measuring toothed-wheel

tooth number z	module m [mm]	OD d <sub>a</sub> [mm]	ID standard [mm]	ID d <sub>i</sub> max. [mm]	collar d <sub>r</sub> [mm]
100	0.5	51.0	12 H7	20 H7	47
125	0.5	63.5	12 H7	30 H7	60
128	0.5	65.0	12 H7	30 H7	61
200	0.5	101.0	12 H7	60 H7	97
250	0.3	75.6	12 H7	40 H7	72
250	0.5	126.0	25 H7	85 H7	122
256	0.3	77.4	12 H7	40 H7	74
256	0.5	129.0	25 H7	90 H7	125
360	0.3	108.6	25 H7	70 H7	105
500	0.3	150.6	25 H7	110 H7	147
512	0.3	154.2	25 H7	110 H7	151

## Dimensioned drawing measuring toothed-wheel

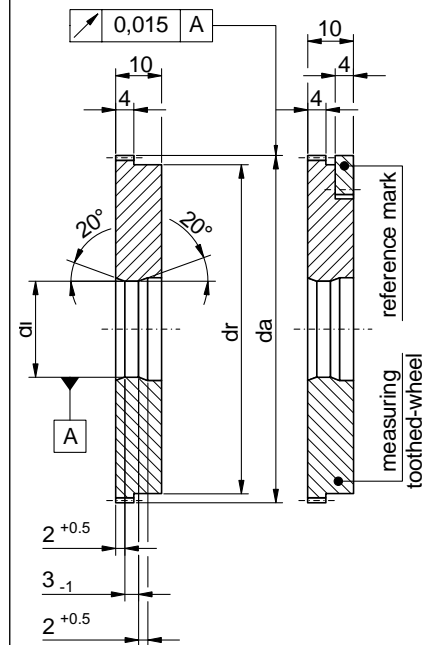

## Type code

ZA	-	-	----	-----	Description
					<b>Inside diameter</b> 0 1 2 . 0 e. g. (see chart at the top)
					<b>Tooth number</b> 0 1 0 0 e. g. (see chart at the top)
					<b>Module</b> 3 module 0.3 5 module 0.5
					<b>Reference mark</b> - without reference mark N with reference mark

## Custom-made measuring toothed-wheel

We also supply custom-made measuring toothed-wheels according to our customers' specification. For this purpose we require precise data on the toothed wheel. Please fill in the form on pages 6/7.